

Automotive Data Solutions Inc.

INSTALL GUIDE ADS-AL(TB)-TL5-EN

TL5

AVAILABLE FOR: ADS-AL CA

Rev. Date: February 17, 2015

Doc. No.: ##20881##

U.S. PATENT NO. 8,856,780

PLEASE VISIT WWW.IDATALINK.COM FOR COMPLETE PRODUCT DETAILS

The brand names and logos found in this guide are property of their respective owners. Automotive Data Solutions Inc. © 2015

SCION



TOYOTA

NOTICE: The manufacturer will accept no responsibility for any electrical damage resulting from improper installation of this product, be that either damage to the vehicle itself or to the installed device. This device must be installed by a certified technician. This guide has been written for properly trained technicians; a certain level of skill & knowledge is therefore assumed. Please review the Installation Guide carefully before beginning any work.

INSTALL TYPE SELECTION

MAKE	MODEL	YEAR	INSTALL TYPE	DATA IMMOBILIZER BYPASS	FEATURES
SCION	iQ STD key (80 bit)	12-15	1	•	
	tC STD key (80 bit)	11-15	1	•	
	xB STD key (80 bit)	11-15	1	•	
	xD STD key (80 bit)	11-14	1	•	
TOYOTA	4Runner STD key (80 bit)	10-15	1	•	
	Camry STD key (80 bit)	10-11	1	•	
	Camry STD key (80 bit)	12-14	1	•	
	Corolla STD key (80 bit)	12-13	1	•	
	FJ Cruiser STD key (80 bit)	10-14	1	•	
	Highlander STD key (80 bit)	11-13	1	•	
	Highlander Hybrid STD key (80 bit)	12-13	1	•	
	Matrix STD key (80 bit)	12-14	1	•	
	Prius C STD key (80 bit)	12-14	1	•	
	RAV4 STD key (80 bit)	11-12	1	•	
	Sequoia STD key (80 bit)	11-14	2	•	
	Sienna STD key (80 bit)	11-14	2	•	
	Tacoma STD key (80 bit)	11-14	1	•	
	Tundra STD key (80 bit)	11-15	2	•	
	Venza STD key (80 bit)	10-15	1	•	
	Yaris Hatchback STD key (80 bit)	11	1	•	
	Yaris Hatchback STD key (80 bit)	12-14	1	•	
Yaris Sedan STD key (80 bit)	11-12	1	•		

NOTE

The security light may turn ON during the remote start sequence. It will turn OFF after the takeover procedure is completed.

COMPONENT LOCATOR

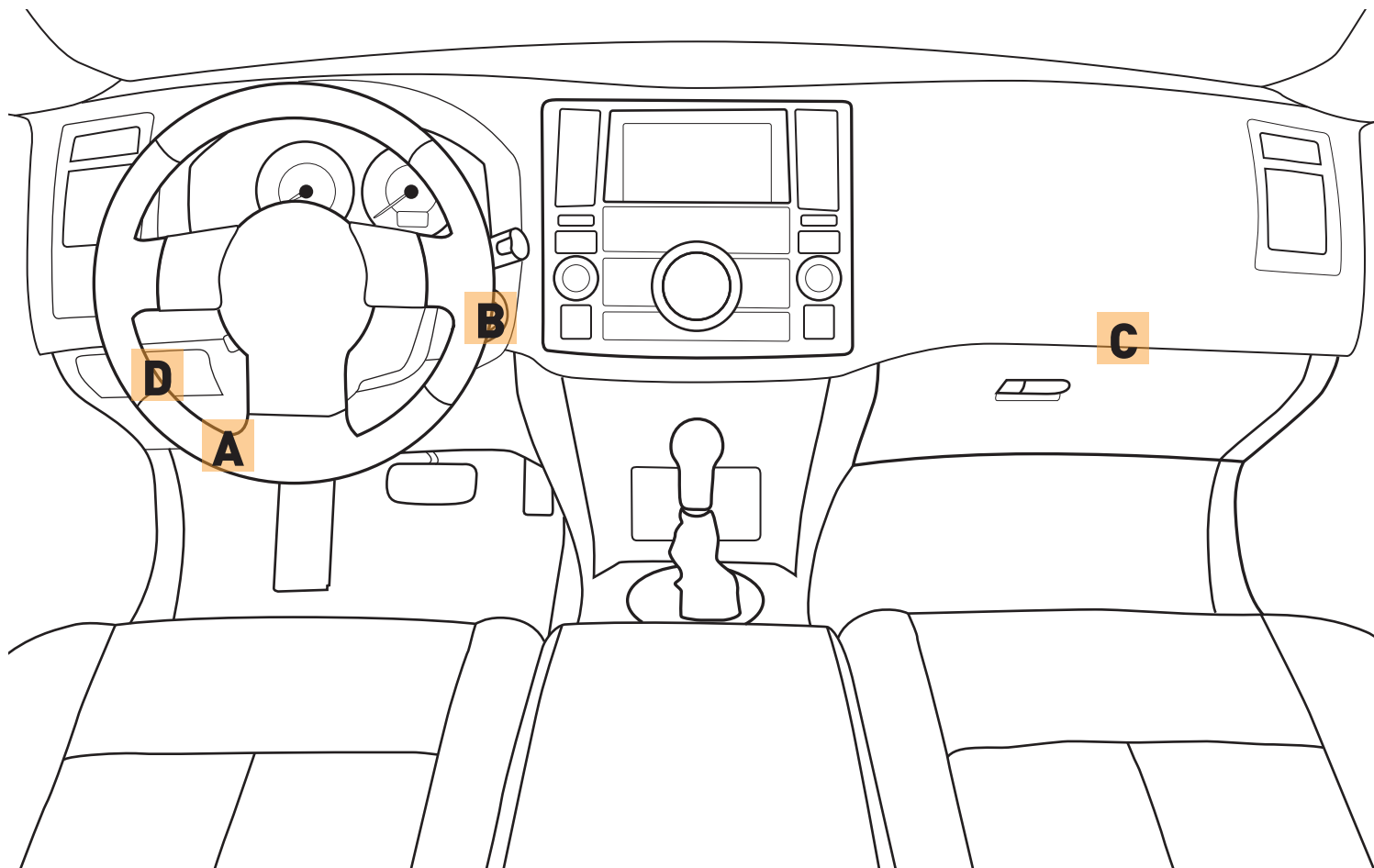

WARNING: VALET KEYS ARE NOT COMPATIBLE

40 BIT VALET KEY

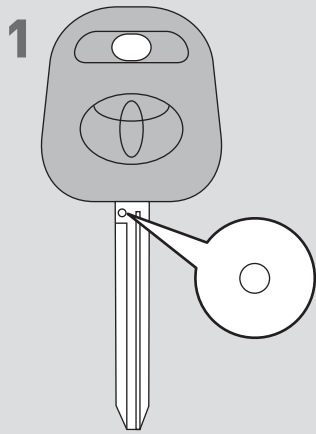

The 40 bit valet key is GRAY and has a dot or "O" stamped on the metal part of the key.

This key is NOT compatible with this firmware.

2

Use a regular key and a compatible firmware solution.

80 BIT VALET KEY

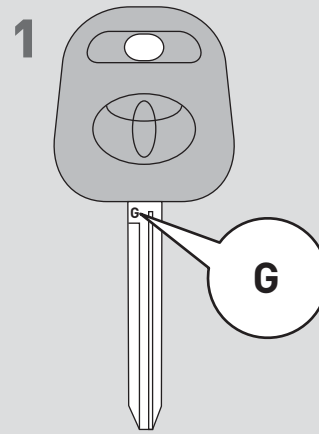

The 80 bit valet key is GRAY and has "G" stamped on the metal part of the key.

This key is NOT compatible with this firmware.

2

Use a regular key and a compatible firmware solution.

IDENTIFY REGULAR KEY

40 BIT REGULAR KEY

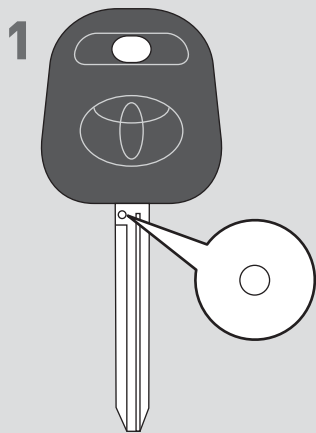

The 40 bit regular key is BLACK and has a dot or "O" stamped on the metal part of the key.

This key is NOT compatible with this firmware.

2

Use a compatible firmware solution.

80 BIT REGULAR KEY

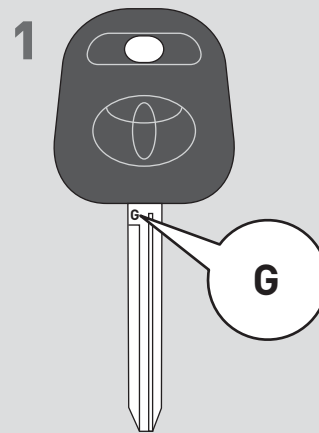

The 80 bit regular key is BLACK and has "G" stamped on the metal part of the key.

This key is compatible with this firmware.

2

Proceed with installation.

TYPE 1 - WIRE CROSS REFERENCE CHART

MAKE	MODEL	YEAR	WIRE DESCRIPTION	CONNECTOR NAME	CONNECTOR COLOR	CONNECTOR TYPE	POSITION	WIRE COLOR	POLARITY	MODULE LOCATION	COMPONENT LOCATOR
SCION	iQ STD key	12-15	Ignition B	D28	White	08 pin	04	LtBlue	(+)	Ignition connector	A
			Immobilizer	ODBII	White	16 pin	07	Red	(DATA)	ODBII	B
	tC STD key	11-15	Ignition B	C5	White	08 pin	04	Gray	(+)	Ignition connector	A
			Immobilizer	OBDII	White	16 pin	07	White or Purple	(DATA)	OBDII	B
xB STD key	11-15	Ignition B	C5	White	08 pin	04	White	(+)	Ignition connector	A	
		Immobilizer	C14	White	16 pin	07	White	(DATA)	OBDII	B	
xD STD key	11-14	Ignition B	F9	White	08 pin	01	Green	(+)	Ignition connector	A	
		Immobilizer	F16	White	16 pin	07	White or Blue	(DATA)	OBDII	B	
4Runner STD key	10-15	Ignition B	F15	White	08 pin	04	Purple	(+)	Ignition connector	A	
		Immobilizer	F13	White	16 pin	07	Green	(DATA)	OBDII	B	
Camry STD key	10-11	Ignition B	E23	White	08 pin	01	Pink	(+)	Ignition connector	A	
		Immobilizer	E10	Black	16 pin	07	Gray	(DATA)	OBDII	B	
Camry STD key	12-14	Ignition B	i36	White	08 pin	01	Pink	(+)	Ignition connector	A	
		Immobilizer	I39	White	16 pin	07	Gray	(DATA)	OBDII	B	
Corolla STD key	12-13	Ignition B	E4	White	08 pin	04	Green or White	(+)	Ignition connector	A	
		Immobilizer	E11	White	16 pin	07	White	(DATA)	OBDII	B	
FJ Cruiser STD key	10-14	Ignition B	A1	White	08 pin	06	Black/Red	(+)	Ignition connector	A	
		Immobilizer	E1	White	16 pin	07	Red/Yellow	(DATA)	OBDII	B	
Highlander Hybrid STD key	12-13	Ignition B	D70	White	08 pin	06	LtBlue	(+)	Ignition connector	A	
		Immobilizer	D47	White	16 pin	07	Gray	(DATA)	OBDII	B	
Highlander STD key	11-13	Ignition B	D24	White	08 pin	06	LtBlue	(+)	Ignition connector	A	
		Immobilizer	D47	White	16 pin	07	Gray	(DATA)	OBDII	B	
Matrix STD key	12-14	Ignition B	E5	White	08 pin	04	Green	(+)	Ignition connector	A	
		Immobilizer	E15	White	16 pin	07	White	(DATA)	OBDII	B	
Prius C STD key	12-14	Ignition B	G15	White	08 pin	01	LtBlue	(+)	Ignition connector	A	
		Immobilizer	G4	White	16 pin	07	Black	(DATA)	OBDII	B	
RAV4 STD key	11-12	Ignition B	E3	White	08 pin	04	Pink	(+)	Ignition connector	A	
		Immobilizer	E13	White	16 pin	07	White	(DATA)	OBDII	B	
Tacoma STD key	11-14	Ignition B	I7	White	08 pin	06	Black/Red	(+)	Ignition connector	A	
		Immobilizer	D4	White	16 pin	07	White	(DATA)	OBDII	B	
Venza STD key	10-15	Ignition B	D12	White	08 pin	06	Red	(+)	Ignition connector	A	
		Immobilizer	D1	White	16 pin	07	Blue	(DATA)	OBDII	B	
Yaris Hatchback STD key	11	Ignition B	D8	White	08 pin	01	Green	(+)	Ignition connector	A	
		Immobilizer	D15	White	16 pin	07	Blue or Black	(DATA)	OBDII	B	
Yaris Hatchback STD key	12-14	Ignition B	D109	White	08 pin	01	LtBlue	(+)	Ignition connector	A	
		Immobilizer	D102	White	16 pin	07	Black	(DATA)	OBDII	B	
Yaris Sedan STD key	11-12	Ignition B	D8	White	08 pin	01	Green	(+)	Ignition connector	A	
		Immobilizer	D15	White	16 pin	07	Blue or Black	(DATA)	OBDII	B	

TYPE 1 - WIRING DIAGRAM

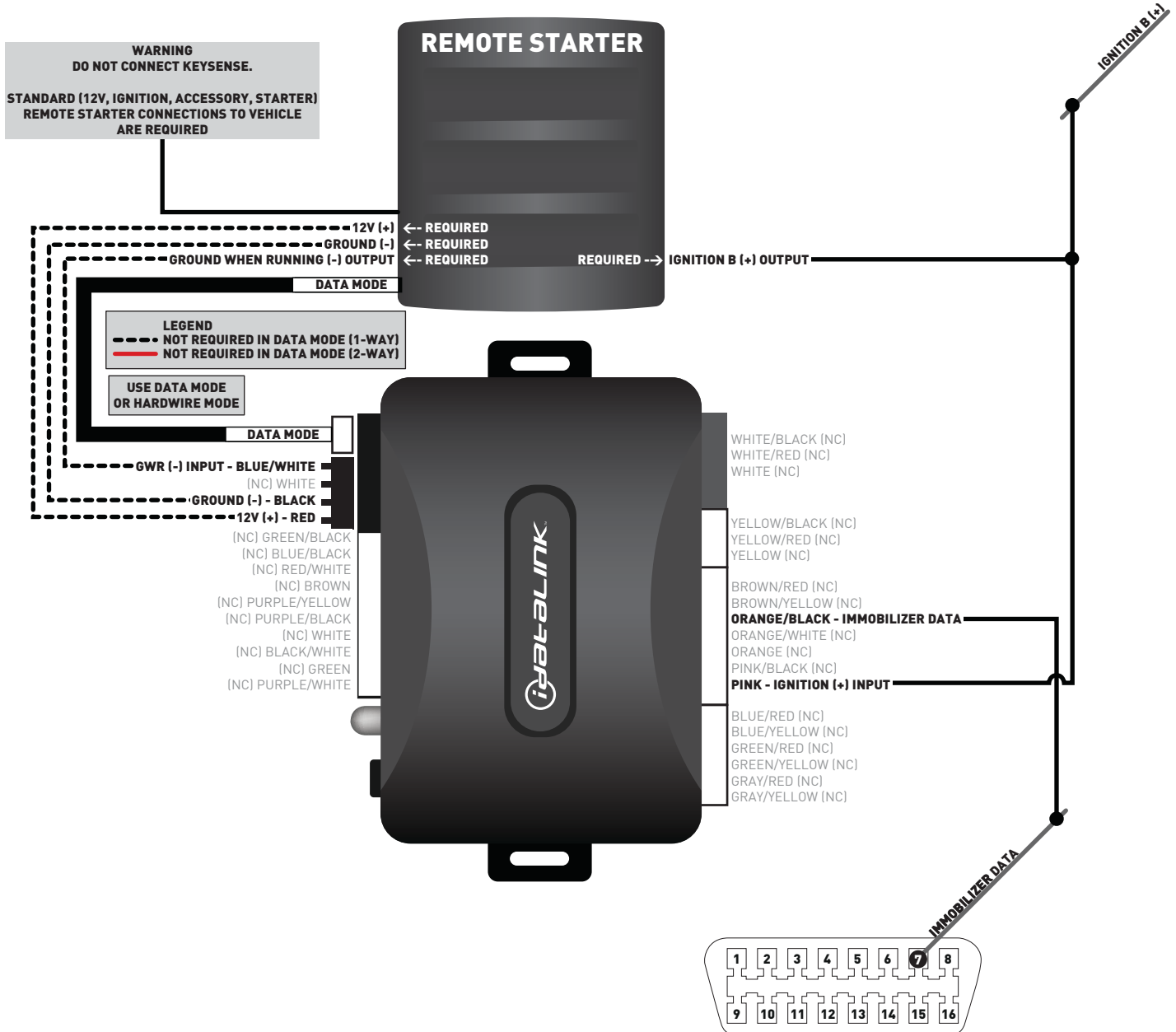

TYPE 2 - WIRE CROSS REFERENCE CHART

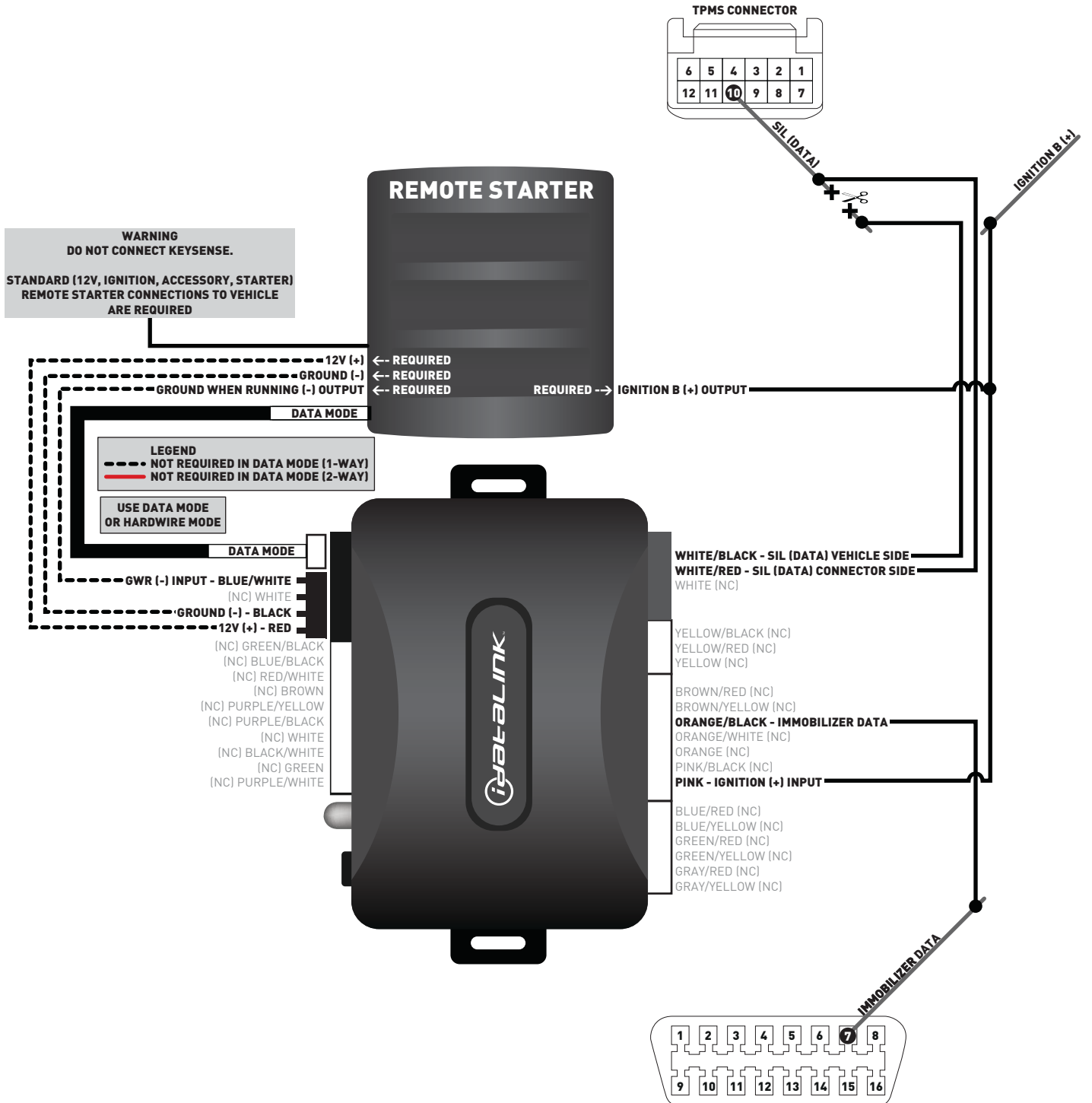

MAKE	MODEL	YEAR	WIRE DESCRIPTION	CONNECTOR NAME	CONNECTOR COLOR	CONNECTOR TYPE	POSITION	WIRE COLOR	POLARITY	MODULE LOCATION	COMPONENT LOCATOR
TOYOTA	Sequoia STD key	11-14	Ignition B	H10	White	08 pin	01	LtGreen	(+)	Ignition connector	B
			Immobilizer	H19	White	16 pin	07	Tan	(DATA)	OBDII	A
			SIL	H40	White	12 pin	10	Blue	(DATA)	TPMS module behind glove box	C
	Sienna STD key	11-14	Ignition B	D27	White	08 pin	04	Yellow	(+)	Ignition connector	B
			Immobilizer	D16	White	16 pin	07	White	(DATA)	OBDII	A
			SIL	D82	White	12 pin	10	White	(DATA)	TPMS module next to driver side fuse box	D
	Tundra STD key	11-15	Ignition B	J9	White	08 pin	01	LtGreen	(+)	Ignition connector	B
			Immobilizer	J17	White	16 pin	07	Tan	(DATA)	OBDII	A
			SIL	J31	White	12 pin	10	Blue	(DATA)	TPMS module behind glove box	C

TYPE 2 - WIRING DIAGRAM

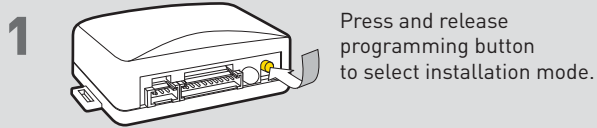

INSTALLATION MODE SELECTION



 LED flashes (1X) once = DATA MODE
 LED flashes (2X) twice = STANDARD HARDWIRE MODE

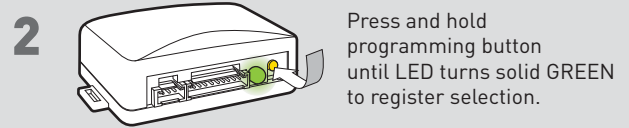

! After registration, follow Factory Reset Procedure to change installation mode and restart this procedure.

MODULE PROGRAMMING PROCEDURE

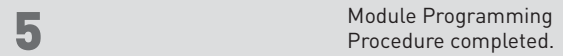
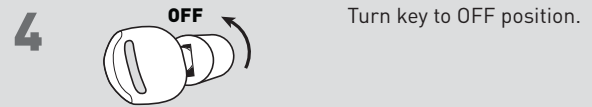
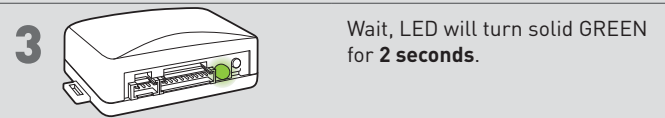
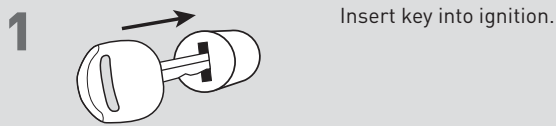

IDENTIFY VEHICLE YEAR

1 Locate the Vehicle Identification Number (VIN), identify the 10th character then match it to its corresponding year.



A	1980	L	1990	Y	2000	A	2010
B	1981	M	1991	1	2001	B	2011
C	1982	N	1992	2	2002	C	2012
D	1983	P	1993	3	2003	D	2013
E	1984	R	1994	4	2004	E	2014
F	1985	S	1995	5	2005	F	2015
G	1986	T	1996	6	2006	G	2016
H	1987	V	1997	7	2007	H	2017
J	1988	W	1998	8	2008	J	2018
K	1989	X	1999	9	2009	K	2019

MODULE DIAGNOSTICS

LED STATUS	DIAGNOSTICS		
	DURING PROGRAMMING	DURING REMOTE START	WITH IGNITION OFF
Flashing RED	Missing/wrong information from firmware or vehicle	Incorrectly programmed	Incorrectly programmed or connected
Solid RED	Waiting for more vehicle information	Incorrectly programmed	Not programmed waiting for more vehicle information
Flashing GREEN	Additional steps required to complete programming	Correctly programmed and operational	False ground when running status from remote starter
Solid GREEN then OFF	Correctly programmed	Reset in progress	Reset in progress
OFF	No activity or already programmed	Invalid ground when running status from remote starter	At rest and ready for a remote start sequence

FACTORY RESET PROCEDURE

- DISCONNECT** all connectors from module **EXCEPT** the black 4-PIN standard or optional data connector.
- DISCONNECT** black 4-PIN standard or optional data connector.
- PRESS AND HOLD** programming button while connecting either 4-PIN standard or optional data connector.
- When LED flashes red, **RELEASE** programming button.

- LED will turn solid red for 2 seconds.
RESET COMPLETED.
 - RECONNECT** all connectors.
 - Repeat programming procedure.
- !** Failure to follow procedure may result with a DTC or a CHECK ENGINE error message.