



HOW TO USE THIS INSTALL GUIDE

- 1** Open the Bookmarks menu and find your vehicle OR scroll down until you find the install guide for your vehicle.
- 2** Print only the pages for your vehicle using the advanced options in the Print menu.
- 3** Install your Maestro RR according to the guide for your vehicle.

WARNING

Pressing the printer icon or “quick printing” this document will print all of the guides in this compilation.



INSTALL GUIDE HYUNDAI ACCENT BASE 2012-2014

RETAINS STEERING WHEEL CONTROLS AND ADDS GAUGES



PRODUCTS REQUIRED

iDatalink Maestro RR Radio Replacement Interface
iDatalink Compatible Radio

OPTIONAL ACCESSORIES

None

PROGRAMMED FIRMWARE

ADS-RR(SI)-HYU01-DS

NOTICE: Automotive Data Solutions Inc. (ADS) recommends having this installation performed by a certified technician. Logos and trademarks used here in are the properties of their respective owners.

WELCOME

Congratulations on the purchase of your iDatalink Maestro RR Radio replacement solution. You are now a few simple steps away from enjoying your new car radio with enhanced features.

Before starting your installation, please ensure that your iDatalink Maestro module is programmed with the correct firmware for your vehicle and that you carefully review the install guide.

Please note that Maestro RR will only retain functionalities that were originally available in the vehicle.

NEED HELP?

 **1 866 427-2999**

 **support@idatalink.com**

 **maestro.idatalink.com/support
www.12voltdata.com/forum**

TABLE OF CONTENTS

Wiring Diagram	3
Vehicle Wire Reference Chart	4

WIRING DIAGRAM

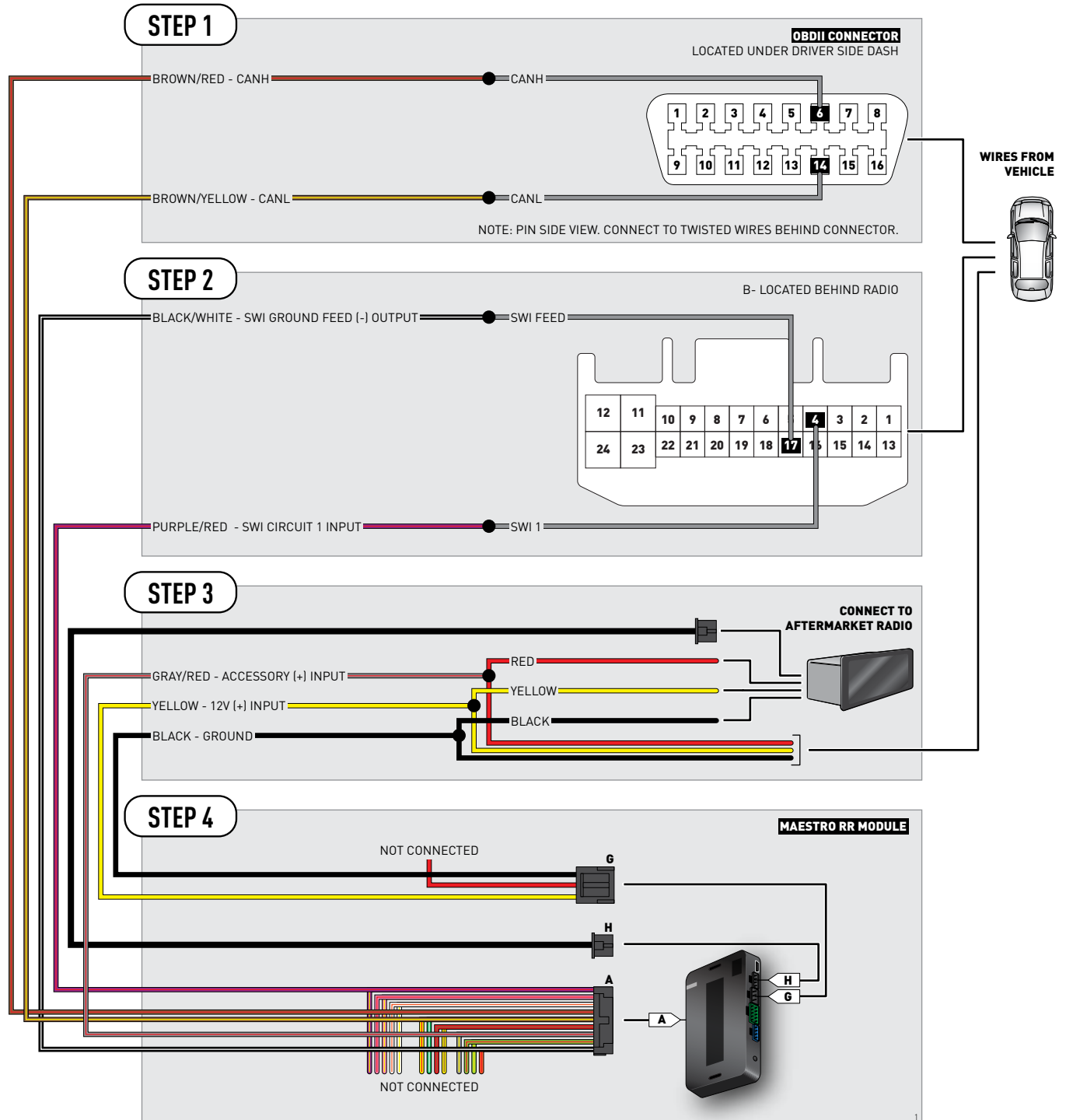

VEHICLE WIRE REFERENCE CHART

Wire Description	Connector Name	Connector Color	Connector Type	Position	Wire Color	Polarity	Wire Location
CanH	A	~	16 pin	06	Green	[DATA]	OBDII connector, under driver side dash
CanL	A	~	16 pin	14	Orange	[DATA]	OBDII connector, under driver side dash
SWI 1	B	~	24 pin	04	Yellow/Orange	[DATA]	Behind radio
SWI Feed	B	~	24 pin	17	Orange	(-)	Behind radio



INSTALL GUIDE HYUNDAI AZERA BASE 2006-2011

RETAINS STEERING WHEEL CONTROLS AND ADDS GAUGES



PRODUCTS REQUIRED

iDatalink Maestro RR Radio Replacement Interface
iDatalink Compatible Radio

OPTIONAL ACCESSORIES

None

PROGRAMMED FIRMWARE

ADS-RR(SI)-HYU01-DS

NOTICE: Automotive Data Solutions Inc. (ADS) recommends having this installation performed by a certified technician. Logos and trademarks used here in are the properties of their respective owners.

WELCOME

Congratulations on the purchase of your iDatalink Maestro RR Radio replacement solution. You are now a few simple steps away from enjoying your new car radio with enhanced features.

Before starting your installation, please ensure that your iDatalink Maestro module is programmed with the correct firmware for your vehicle and that you carefully review the install guide.

Please note that Maestro RR will only retain functionalities that were originally available in the vehicle.

NEED HELP?

 **1 866 427-2999**

 support@idatalink.com

 maestro.idatalink.com/support
www.12voltdata.com/forum

TABLE OF CONTENTS

Wiring Diagram	3
Vehicle Wire Reference Chart	4

WIRING DIAGRAM

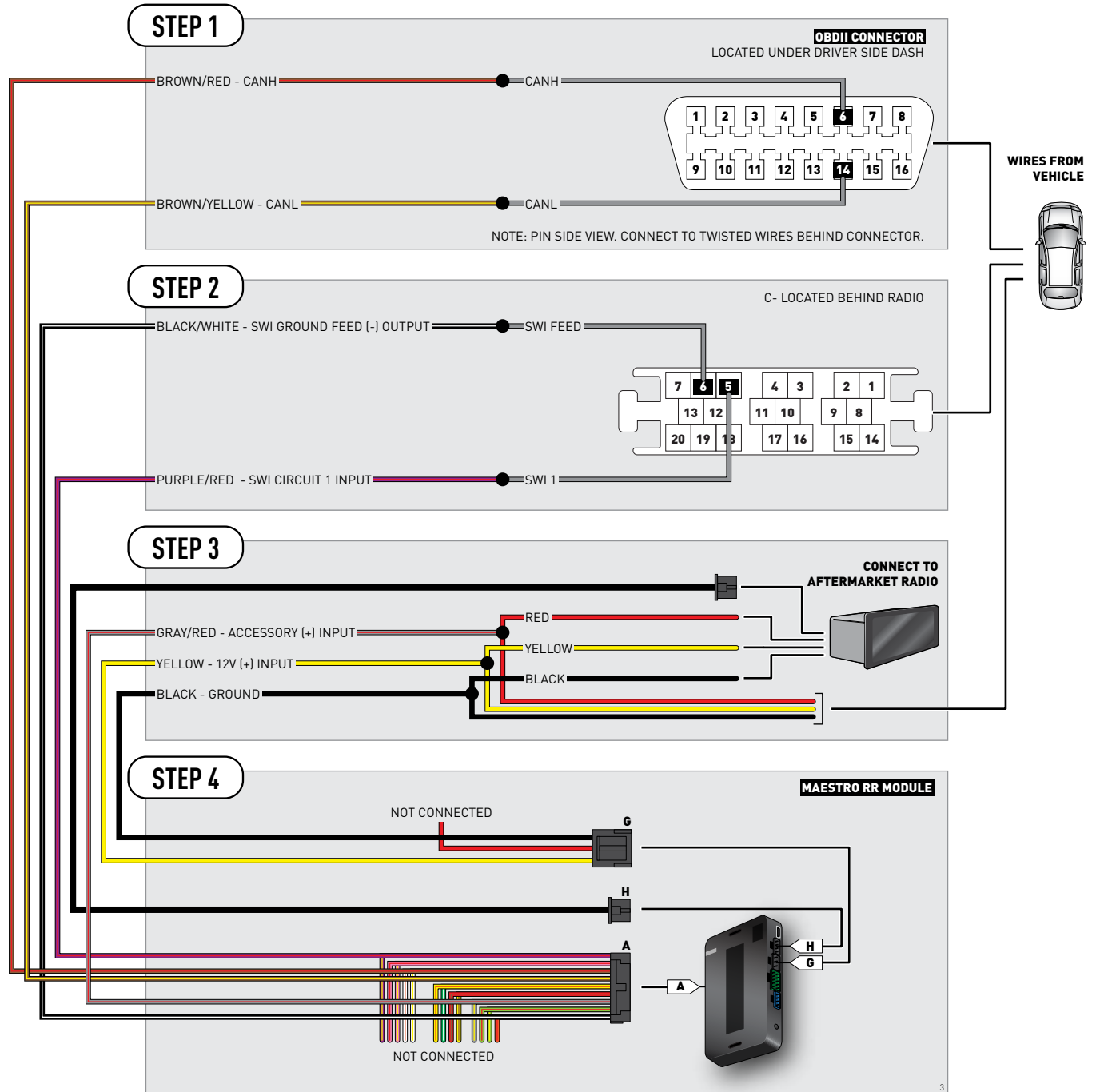

VEHICLE WIRE REFERENCE CHART

Wire Description	Connector Name	Connector Color	Connector Type	Position	Wire Color	Polarity	Wire Location
CanH	A	~	16 pin	06	Black	[DATA]	OBDII connector, under driver side dash
CanL	A	~	16 pin	14	Yellow	[DATA]	OBDII connector, under driver side dash
SWI 1	C	~	20 pin	05	White	[DATA]	Behind radio
SWI Feed	C	~	20 pin	06	White/Black	(-)	Behind radio



INSTALL GUIDE HYUNDAI ELANTRA BASE 2007-2010

RETAINS STEERING WHEEL CONTROLS AND ADDS GAUGES



PRODUCTS REQUIRED

iDatalink Maestro RR Radio Replacement Interface
iDatalink Compatible Radio

OPTIONAL ACCESSORIES

None

PROGRAMMED FIRMWARE

ADS-RR(SI)-HYU01-DS

NOTICE: Automotive Data Solutions Inc. (ADS) recommends having this installation performed by a certified technician. Logos and trademarks used here in are the properties of their respective owners.

WELCOME

Congratulations on the purchase of your iDatalink Maestro RR Radio replacement solution. You are now a few simple steps away from enjoying your new car radio with enhanced features.

Before starting your installation, please ensure that your iDatalink Maestro module is programmed with the correct firmware for your vehicle and that you carefully review the install guide.

Please note that Maestro RR will only retain functionalities that were originally available in the vehicle.

NEED HELP?

 **1 866 427-2999**

 support@idatalink.com

 maestro.idatalink.com/support
www.12voltdata.com/forum

TABLE OF CONTENTS

Wiring Diagram	3
Vehicle Wire Reference Chart	4

WIRING DIAGRAM

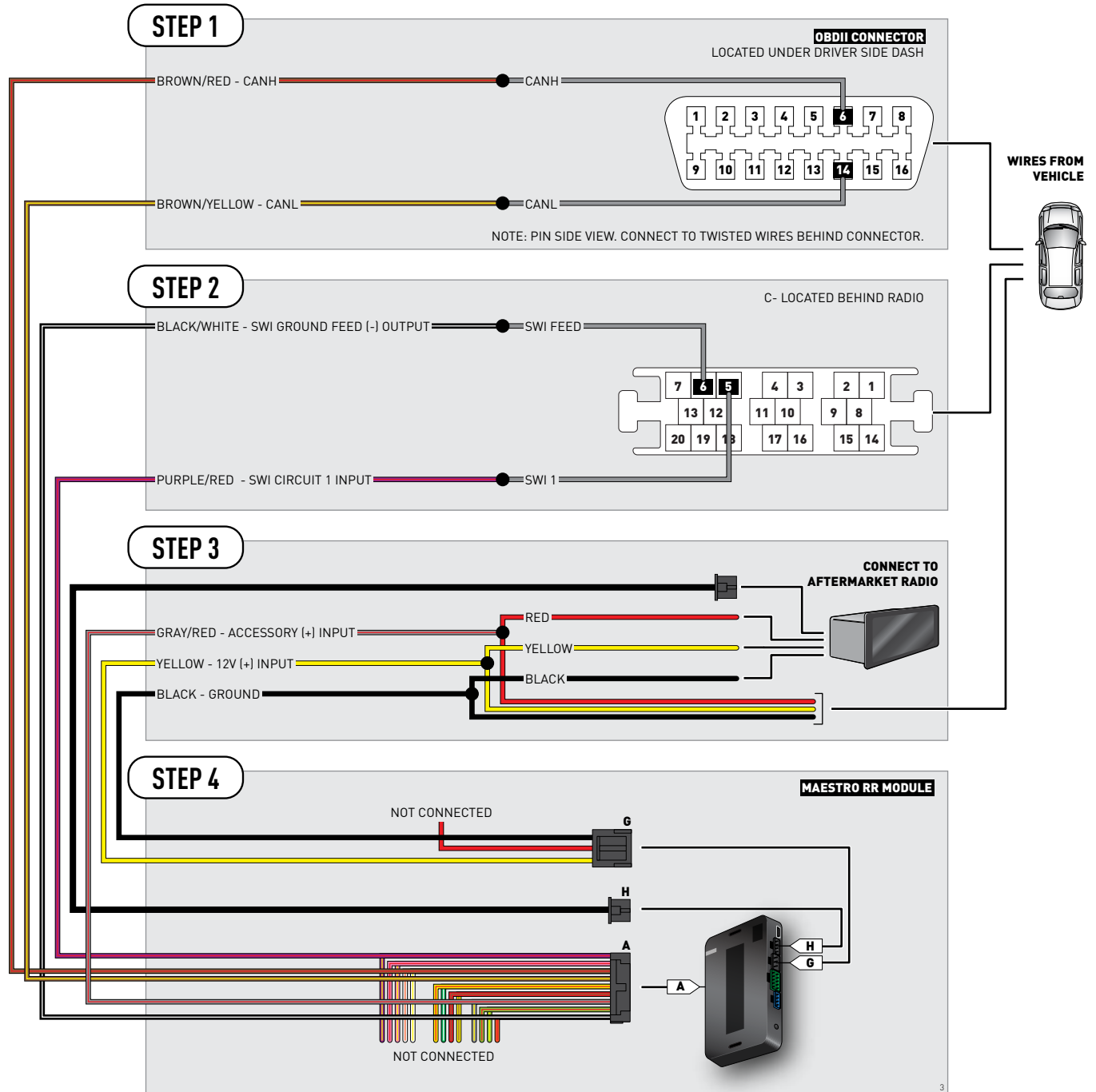

VEHICLE WIRE REFERENCE CHART

Wire Description	Connector Name	Connector Color	Connector Type	Position	Wire Color	Polarity	Wire Location
CanH	A	~	16 pin	06	White	[DATA]	OBDII connector, under driver side dash
CanL	A	~	16 pin	14	Yellow	[DATA]	OBDII connector, under driver side dash
SWI 1	C	~	20 pin	05	Green	[DATA]	Behind radio
SWI Feed	C	~	20 pin	06	Black	(-)	Behind radio



INSTALL GUIDE HYUNDAI ELANTRA BASE 2011-2014

RETAINS STEERING WHEEL CONTROLS AND ADDS GAUGES



PRODUCTS REQUIRED

iDatalink Maestro RR Radio Replacement Interface
iDatalink Compatible Radio

OPTIONAL ACCESSORIES

None

PROGRAMMED FIRMWARE

ADS-RR(SI)-HYU01-DS

NOTICE: Automotive Data Solutions Inc. (ADS) recommends having this installation performed by a certified technician. Logos and trademarks used here in are the properties of their respective owners.

WELCOME

Congratulations on the purchase of your iDatalink Maestro RR Radio replacement solution. You are now a few simple steps away from enjoying your new car radio with enhanced features.

Before starting your installation, please ensure that your iDatalink Maestro module is programmed with the correct firmware for your vehicle and that you carefully review the install guide.

Please note that Maestro RR will only retain functionalities that were originally available in the vehicle.

NEED HELP?

 **1 866 427-2999**

 support@idatalink.com

 maestro.idatalink.com/support
www.12voltdata.com/forum

TABLE OF CONTENTS

Wiring Diagram	3
Vehicle Wire Reference Chart	4

WIRING DIAGRAM

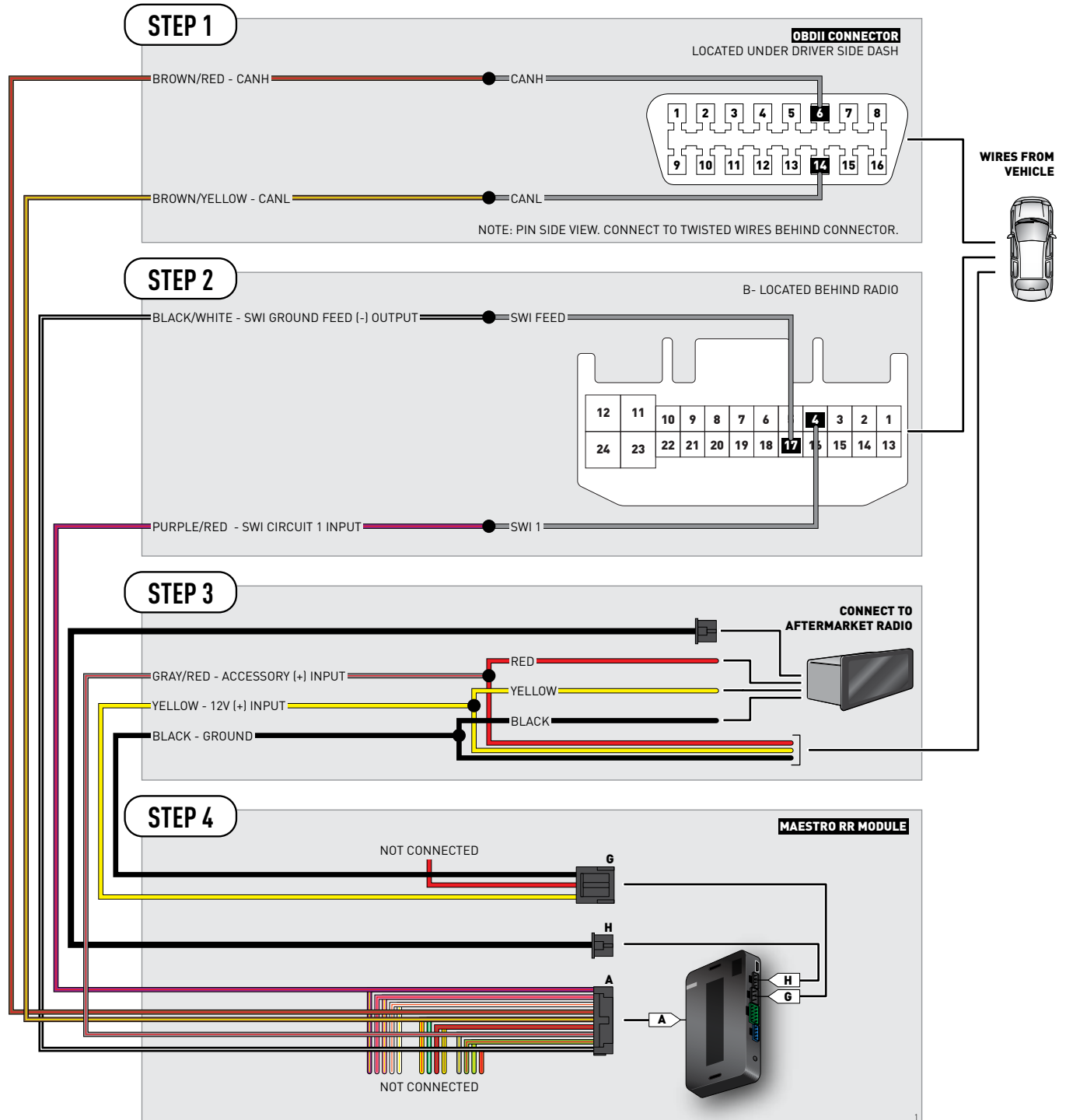

VEHICLE WIRE REFERENCE CHART

Wire Description	Connector Name	Connector Color	Connector Type	Position	Wire Color	Polarity	Wire Location
CanH	A	~	16 pin	06	White	[DATA]	OBDII connector, under driver side dash
CanL	A	~	16 pin	14	Yellow	[DATA]	OBDII connector, under driver side dash
SWI 1	B	~	24 pin	04	Brown	[DATA]	Behind radio
SWI Feed	B	~	24 pin	17	Green	(-)	Behind radio



INSTALL GUIDE

HYUNDAI ELANTRA TOURING

BASE 2007-2012

RETAINS STEERING WHEEL CONTROLS AND ADDS GAUGES



PRODUCTS REQUIRED

iDatalink Maestro RR Radio Replacement Interface
iDatalink Compatible Radio

OPTIONAL ACCESSORIES

None

PROGRAMMED FIRMWARE

ADS-RR(SI)-HYU01-DS

NOTICE: Automotive Data Solutions Inc. (ADS) recommends having this installation performed by a certified technician. Logos and trademarks used here in are the properties of their respective owners.

WELCOME

Congratulations on the purchase of your iDatalink Maestro RR Radio replacement solution. You are now a few simple steps away from enjoying your new car radio with enhanced features.

Before starting your installation, please ensure that your iDatalink Maestro module is programmed with the correct firmware for your vehicle and that you carefully review the install guide.

Please note that Maestro RR will only retain functionalities that were originally available in the vehicle.

NEED HELP?

 **1 866 427-2999**

 support@idatalink.com

 maestro.idatalink.com/support
www.12voltdata.com/forum

TABLE OF CONTENTS

Wiring Diagram	3
Vehicle Wire Reference Chart	4

WIRING DIAGRAM

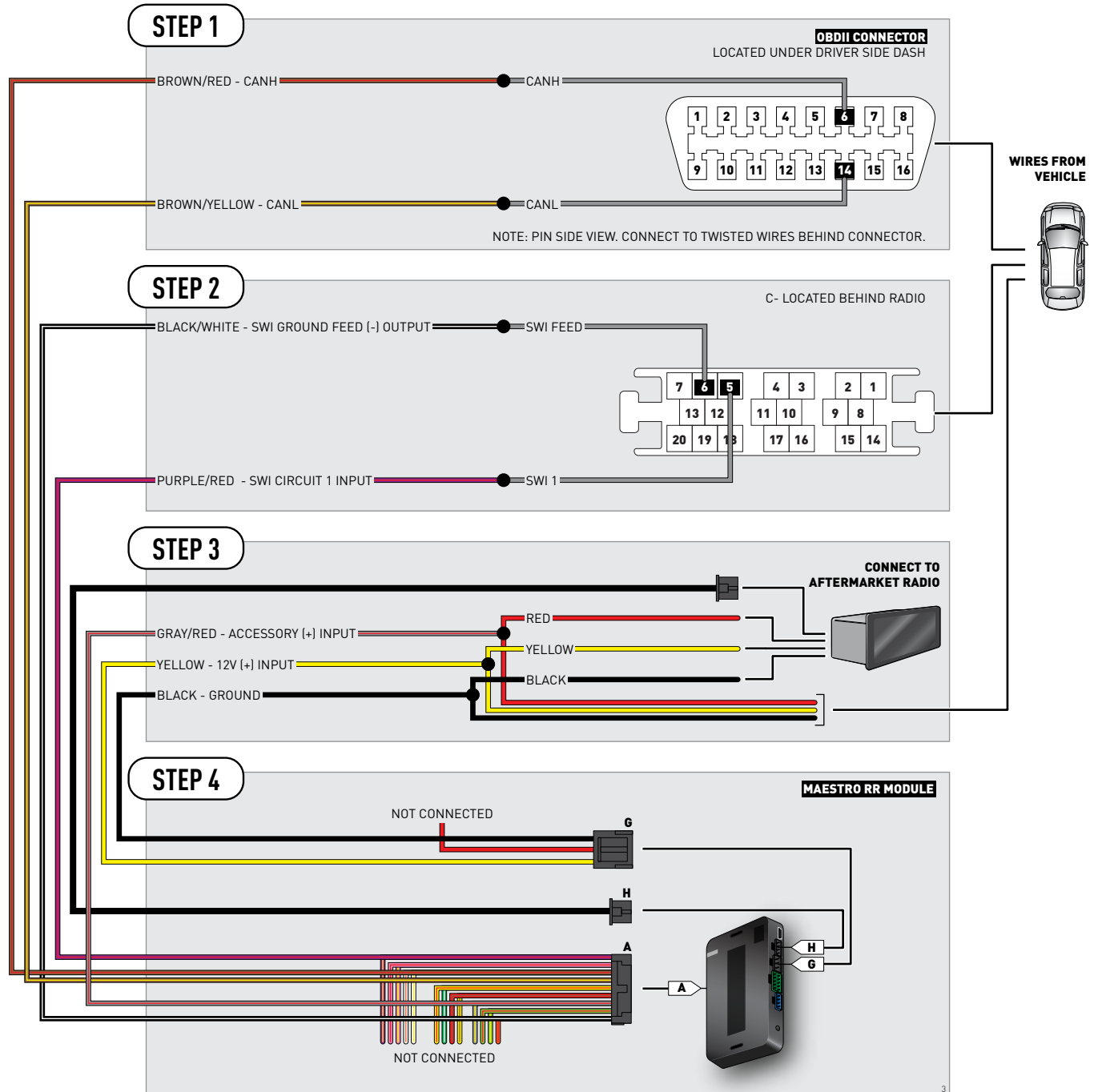

VEHICLE WIRE REFERENCE CHART

Wire Description	Connector Name	Connector Color	Connector Type	Position	Wire Color	Polarity	Wire Location
CanH	A	~	16 pin	06	White	[DATA]	OBDII connector, under driver side dash
CanL	A	~	16 pin	14	Yellow	[DATA]	OBDII connector, under driver side dash
SWI 1	C	~	20 pin	05	Green	[DATA]	Behind radio
SWI Feed	C	~	20 pin	06	Black	(-)	Behind radio



INSTALL GUIDE HYUNDAI GENESIS COUPE BASE 2010-2014

RETAINS STEERING WHEEL CONTROLS AND ADDS GAUGES



PRODUCTS REQUIRED

iDatalink Maestro RR Radio Replacement Interface
iDatalink Compatible Radio

OPTIONAL ACCESSORIES

None

PROGRAMMED FIRMWARE

ADS-RR(SI)-HYU01-DS

NOTICE: Automotive Data Solutions Inc. (ADS) recommends having this installation performed by a certified technician. Logos and trademarks used here in are the properties of their respective owners.

WELCOME

Congratulations on the purchase of your iDatalink Maestro RR Radio replacement solution. You are now a few simple steps away from enjoying your new car radio with enhanced features.

Before starting your installation, please ensure that your iDatalink Maestro module is programmed with the correct firmware for your vehicle and that you carefully review the install guide.

Please note that Maestro RR will only retain functionalities that were originally available in the vehicle.

NEED HELP?

 **1 866 427-2999**

 support@idatalink.com

 maestro.idatalink.com/support
www.12voltdata.com/forum

TABLE OF CONTENTS

Wiring Diagram	3
Vehicle Wire Reference Chart	4

WIRING DIAGRAM

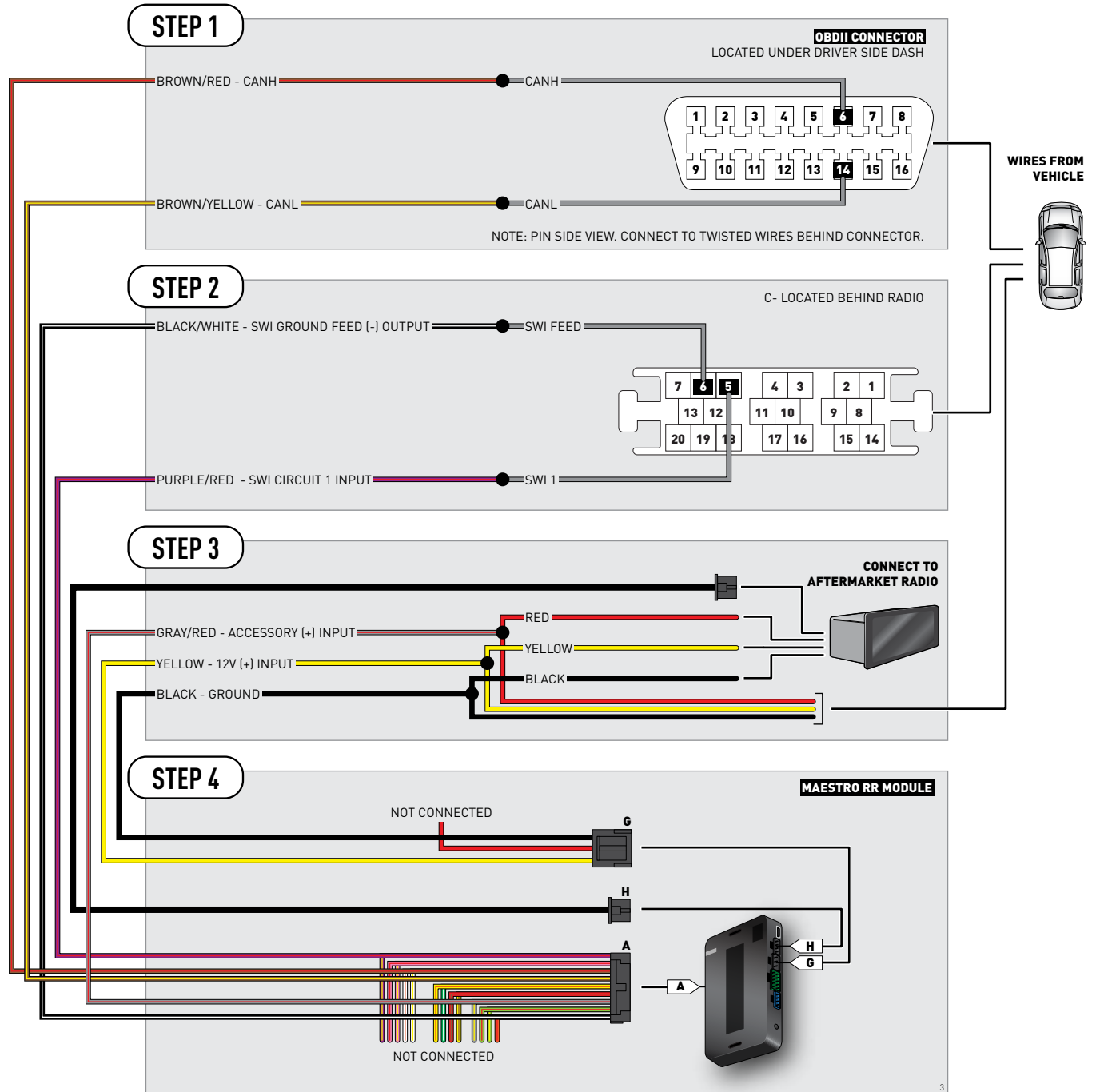

VEHICLE WIRE REFERENCE CHART

Wire Description	Connector Name	Connector Color	Connector Type	Position	Wire Color	Polarity	Wire Location
CanH	A	~	16 pin	06	Red	(DATA)	OBDII connector, under driver side dash
CanL	A	~	16 pin	14	Blue	(DATA)	OBDII connector, under driver side dash
SWI 1	C	~	20 pin	05	Brown	(DATA)	Behind radio
SWI Feed	C	~	20 pin	06	Black/Orange	(-)	Behind radio



INSTALL GUIDE HYUNDAI SANTA FE BASE 2007-2009

RETAINS STEERING WHEEL CONTROLS AND ADDS GAUGES



PRODUCTS REQUIRED

iDatalink Maestro RR Radio Replacement Interface
iDatalink Compatible Radio

OPTIONAL ACCESSORIES

None

PROGRAMMED FIRMWARE

ADS-RR(SI)-HYU01-DS

NOTICE: Automotive Data Solutions Inc. (ADS) recommends having this installation performed by a certified technician. Logos and trademarks used here in are the properties of their respective owners.

WELCOME

Congratulations on the purchase of your iDatalink Maestro RR Radio replacement solution. You are now a few simple steps away from enjoying your new car radio with enhanced features.

Before starting your installation, please ensure that your iDatalink Maestro module is programmed with the correct firmware for your vehicle and that you carefully review the install guide.

Please note that Maestro RR will only retain functionalities that were originally available in the vehicle.

NEED HELP?

 **1 866 427-2999**

 support@idatalink.com

 maestro.idatalink.com/support
www.12voltdata.com/forum

TABLE OF CONTENTS

Wiring Diagram	3
Vehicle Wire Reference Chart	4

WIRING DIAGRAM

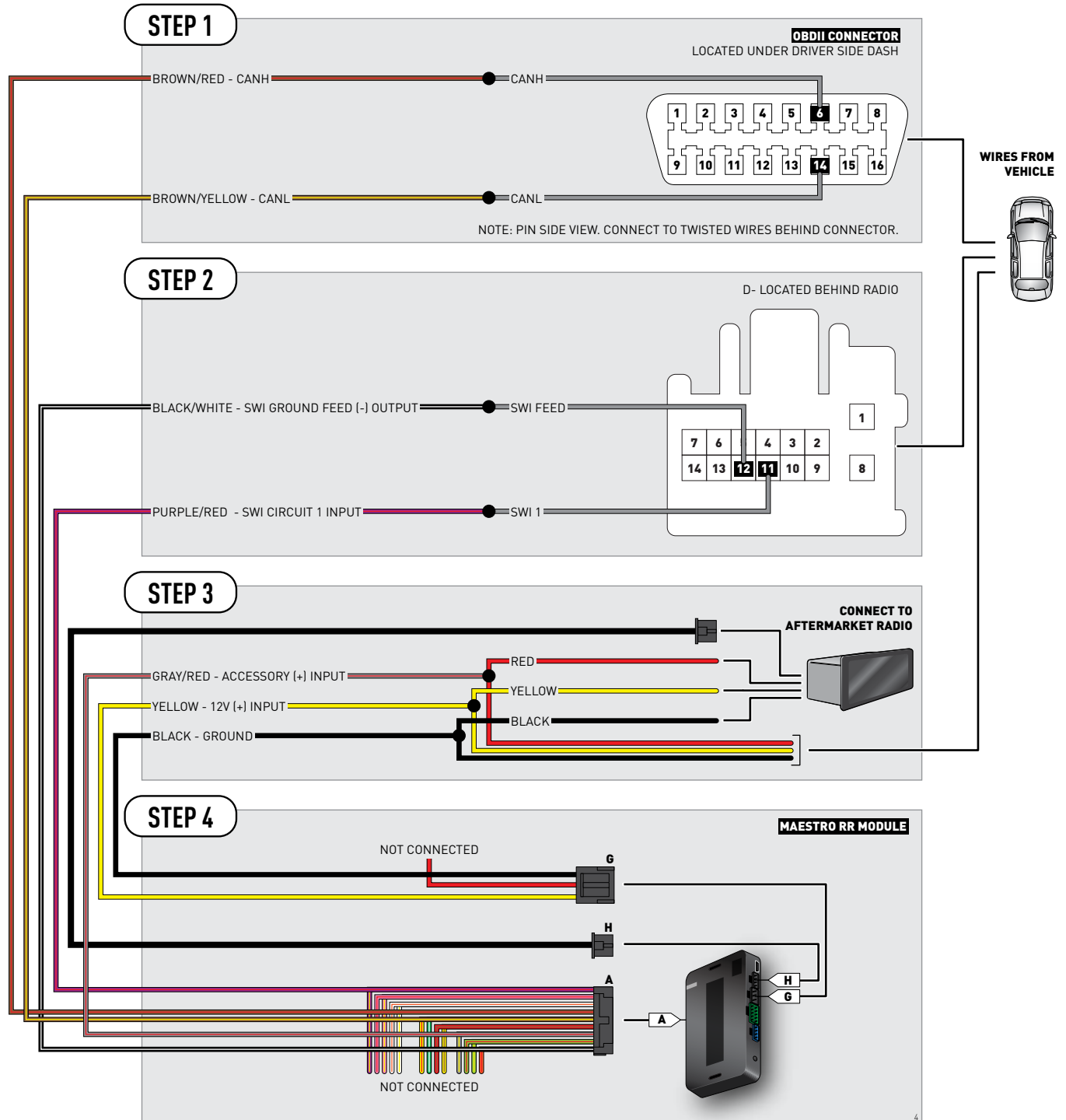

VEHICLE WIRE REFERENCE CHART

Wire Description	Connector Name	Connector Color	Connector Type	Position	Wire Color	Polarity	Wire Location
CanH	A	~	16 pin	06	Red/Black	(DATA)	OBDII connector, under driver side dash
CanL	A	~	16 pin	14	Red	(DATA)	OBDII connector, under driver side dash
SWI 1	D	~	20 pin	11	Blue	(DATA)	Behind radio
SWI Feed	D	~	20 pin	12	Gray	(-)	Behind radio



INSTALL GUIDE HYUNDAI SANTA FE BASE 2010-2014

RETAINS STEERING WHEEL CONTROLS AND ADDS GAUGES



PRODUCTS REQUIRED

iDatalink Maestro RR Radio Replacement Interface
iDatalink Compatible Radio

OPTIONAL ACCESSORIES

None

PROGRAMMED FIRMWARE

ADS-RR(SI)-HYU01-DS

NOTICE: Automotive Data Solutions Inc. (ADS) recommends having this installation performed by a certified technician. Logos and trademarks used here in are the properties of their respective owners.

WELCOME

Congratulations on the purchase of your iDatalink Maestro RR Radio replacement solution. You are now a few simple steps away from enjoying your new car radio with enhanced features.

Before starting your installation, please ensure that your iDatalink Maestro module is programmed with the correct firmware for your vehicle and that you carefully review the install guide.

Please note that Maestro RR will only retain functionalities that were originally available in the vehicle.

NEED HELP?

 **1 866 427-2999**

 **support@idatalink.com**

 **maestro.idatalink.com/support
www.12voltdata.com/forum**

TABLE OF CONTENTS

Wiring Diagram	3
Vehicle Wire Reference Chart	4

WIRING DIAGRAM

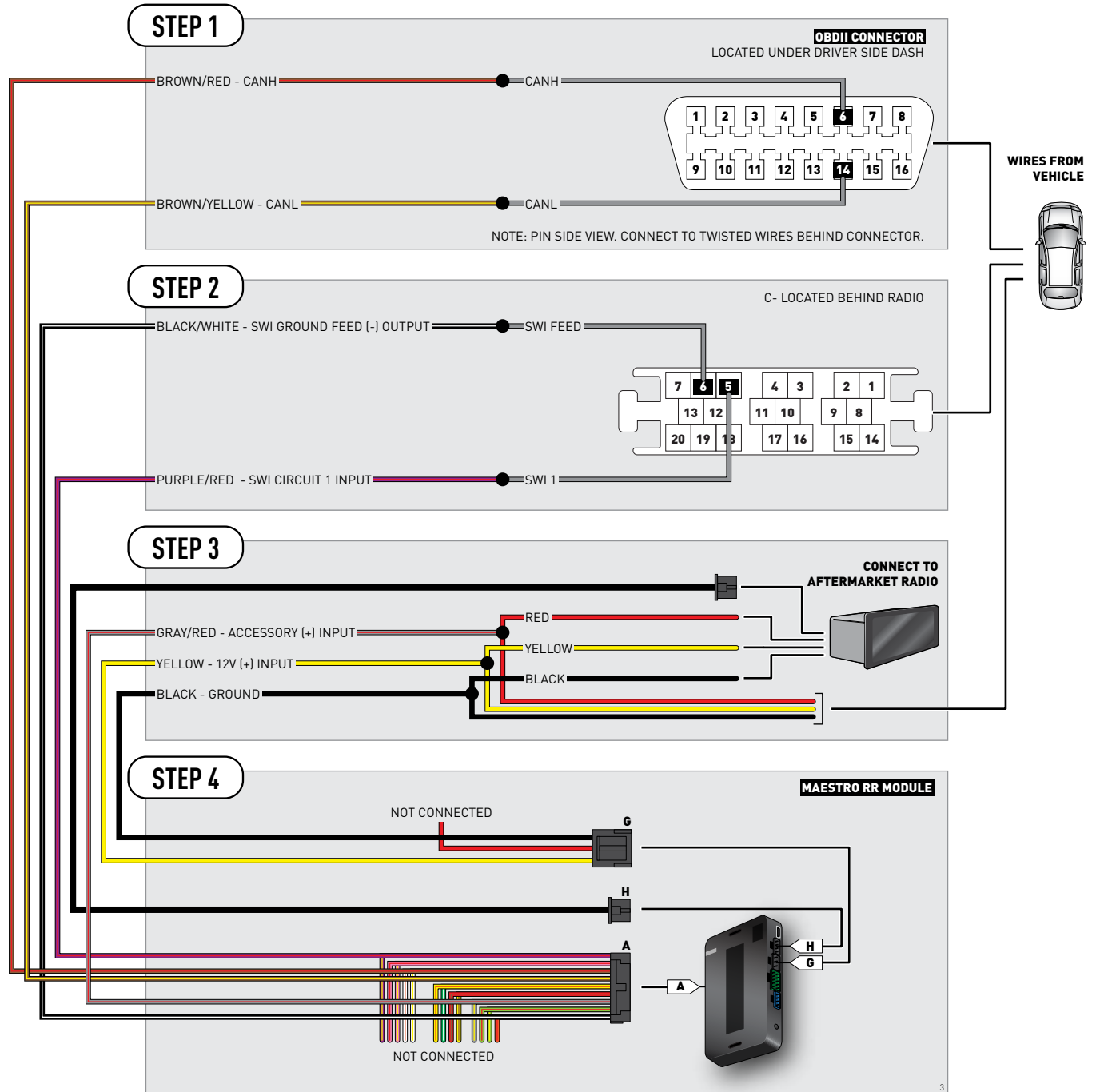

VEHICLE WIRE REFERENCE CHART

Wire Description	Connector Name	Connector Color	Connector Type	Position	Wire Color	Polarity	Wire Location
CanH	A	~	16 pin	06	Blue	(DATA)	OBDII connector, under driver side dash
CanL	A	~	16 pin	14	Orange	(DATA)	OBDII connector, under driver side dash
SWI 1	C	~	20 pin	05	Blue	(DATA)	Behind radio
SWI Feed	C	~	20 pin	06	Gray	(-)	Behind radio



INSTALL GUIDE HYUNDAI SONATA BASE 2006-2010

RETAINS STEERING WHEEL CONTROLS AND ADDS GAUGES



PRODUCTS REQUIRED

iDatalink Maestro RR Radio Replacement Interface
iDatalink Compatible Radio

OPTIONAL ACCESSORIES

None

PROGRAMMED FIRMWARE

ADS-RR(SI)-HYU01-DS

NOTICE: Automotive Data Solutions Inc. (ADS) recommends having this installation performed by a certified technician. Logos and trademarks used here in are the properties of their respective owners.

WELCOME

Congratulations on the purchase of your iDatalink Maestro RR Radio replacement solution. You are now a few simple steps away from enjoying your new car radio with enhanced features.

Before starting your installation, please ensure that your iDatalink Maestro module is programmed with the correct firmware for your vehicle and that you carefully review the install guide.

Please note that Maestro RR will only retain functionalities that were originally available in the vehicle.

NEED HELP?

 **1 866 427-2999**

 support@idatalink.com

 maestro.idatalink.com/support
www.12voltdata.com/forum

TABLE OF CONTENTS

Wiring Diagram	3
Vehicle Wire Reference Chart	4

WIRING DIAGRAM

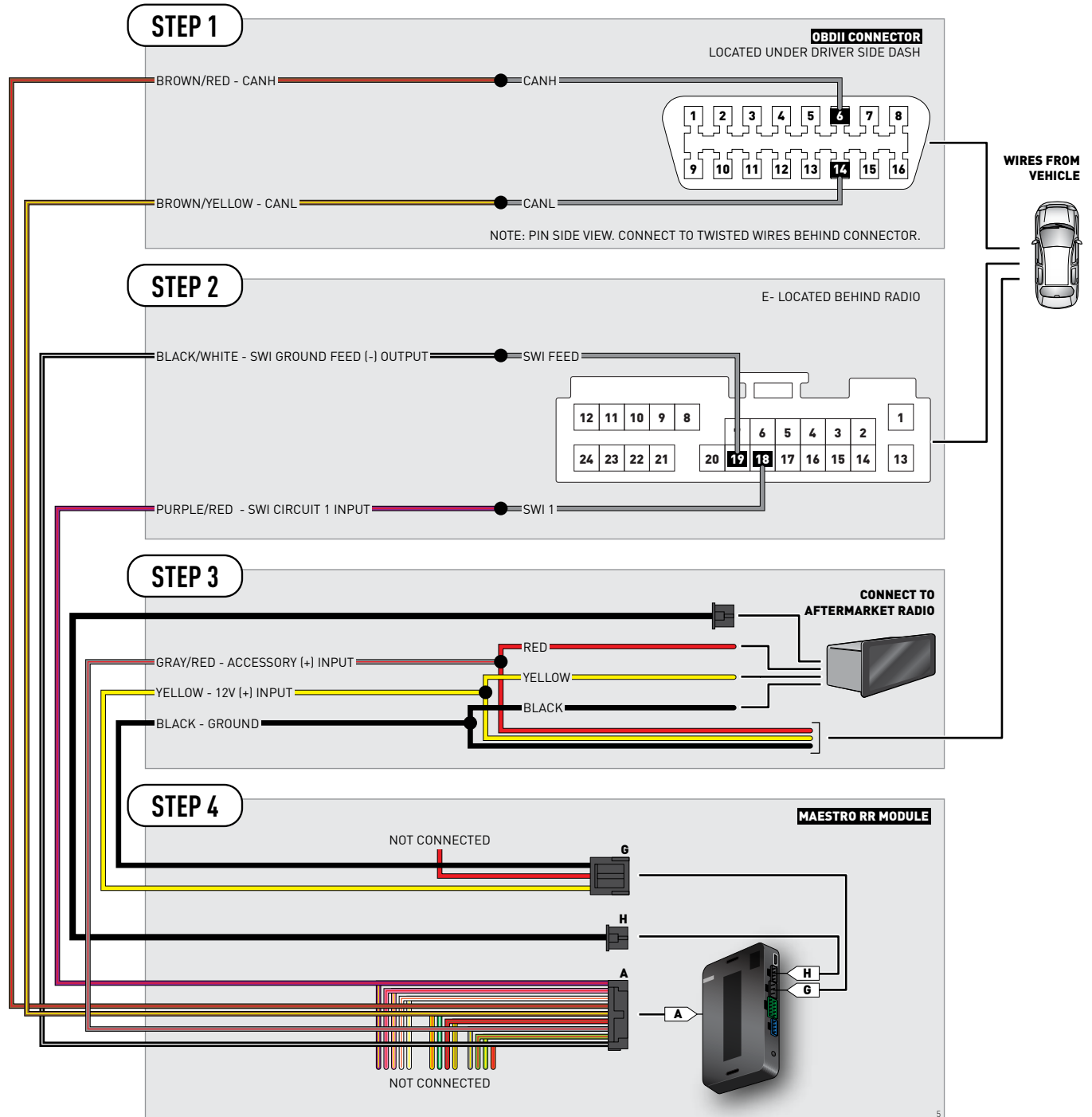

VEHICLE WIRE REFERENCE CHART

Wire Description	Connector Name	Connector Color	Connector Type	Position	Wire Color	Polarity	Wire Location
CanH	A	~	16 pin	06	White	[DATA]	OBDII connector, under driver side dash
CanL	A	~	16 pin	14	Yellow	[DATA]	OBDII connector, under driver side dash
SWI 1	E	~	24 pin	18	Brown	[DATA]	Behind radio
SWI Feed	E	~	24 pin	19	Green	(-)	Behind radio



INSTALL GUIDE HYUNDAI SONATA BASE 2011-2014

RETAINS STEERING WHEEL CONTROLS AND ADDS GAUGES



PRODUCTS REQUIRED

iDatalink Maestro RR Radio Replacement Interface
iDatalink Compatible Radio

OPTIONAL ACCESSORIES

None

PROGRAMMED FIRMWARE

ADS-RR(SI)-HYU01-DS

NOTICE: Automotive Data Solutions Inc. (ADS) recommends having this installation performed by a certified technician. Logos and trademarks used here in are the properties of their respective owners.

WELCOME

Congratulations on the purchase of your iDatalink Maestro RR Radio replacement solution. You are now a few simple steps away from enjoying your new car radio with enhanced features.

Before starting your installation, please ensure that your iDatalink Maestro module is programmed with the correct firmware for your vehicle and that you carefully review the install guide.

Please note that Maestro RR will only retain functionalities that were originally available in the vehicle.

NEED HELP?

 **1 866 427-2999**

 **support@idatalink.com**

 **maestro.idatalink.com/support**
www.12voltdata.com/forum

TABLE OF CONTENTS

Wiring Diagram	3
Vehicle Wire Reference Chart	4

WIRING DIAGRAM

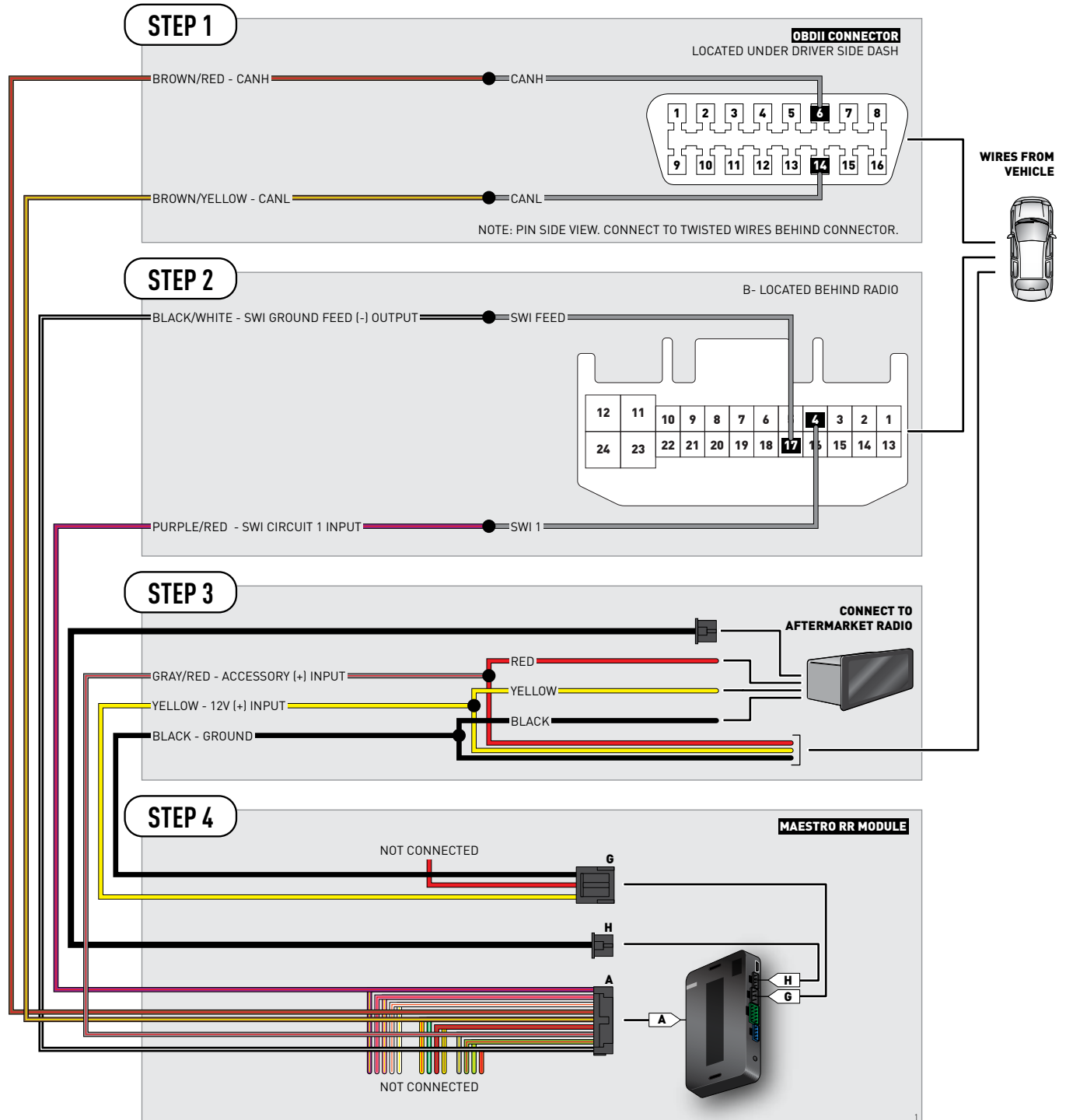

VEHICLE WIRE REFERENCE CHART

Wire Description	Connector Name	Connector Color	Connector Type	Position	Wire Color	Polarity	Wire Location
CanH	A	~	16 pin	06	White	[DATA]	OBDII connector, under driver side dash
CanL	A	~	16 pin	14	Yellow	[DATA]	OBDII connector, under driver side dash
SWI 1	B	~	24 pin	04	Brown	[DATA]	Behind radio
SWI Feed	B	~	24 pin	17	Green	(-)	Behind radio



INSTALL GUIDE HYUNDAI TUCSON BASE 2010-2014

RETAINS STEERING WHEEL CONTROLS AND ADDS GAUGES



PRODUCTS REQUIRED

iDatalink Maestro RR Radio Replacement Interface
iDatalink Compatible Radio

OPTIONAL ACCESSORIES

None

PROGRAMMED FIRMWARE

ADS-RR(SI)-HYU01-DS

NOTICE: Automotive Data Solutions Inc. (ADS) recommends having this installation performed by a certified technician. Logos and trademarks used here in are the properties of their respective owners.

WELCOME

Congratulations on the purchase of your iDatalink Maestro RR Radio replacement solution. You are now a few simple steps away from enjoying your new car radio with enhanced features.

Before starting your installation, please ensure that your iDatalink Maestro module is programmed with the correct firmware for your vehicle and that you carefully review the install guide.

Please note that Maestro RR will only retain functionalities that were originally available in the vehicle.

NEED HELP?

 **1 866 427-2999**

 **support@idatalink.com**

 **maestro.idatalink.com/support
www.12voltdata.com/forum**

TABLE OF CONTENTS

Wiring Diagram	3
Vehicle Wire Reference Chart	4

WIRING DIAGRAM

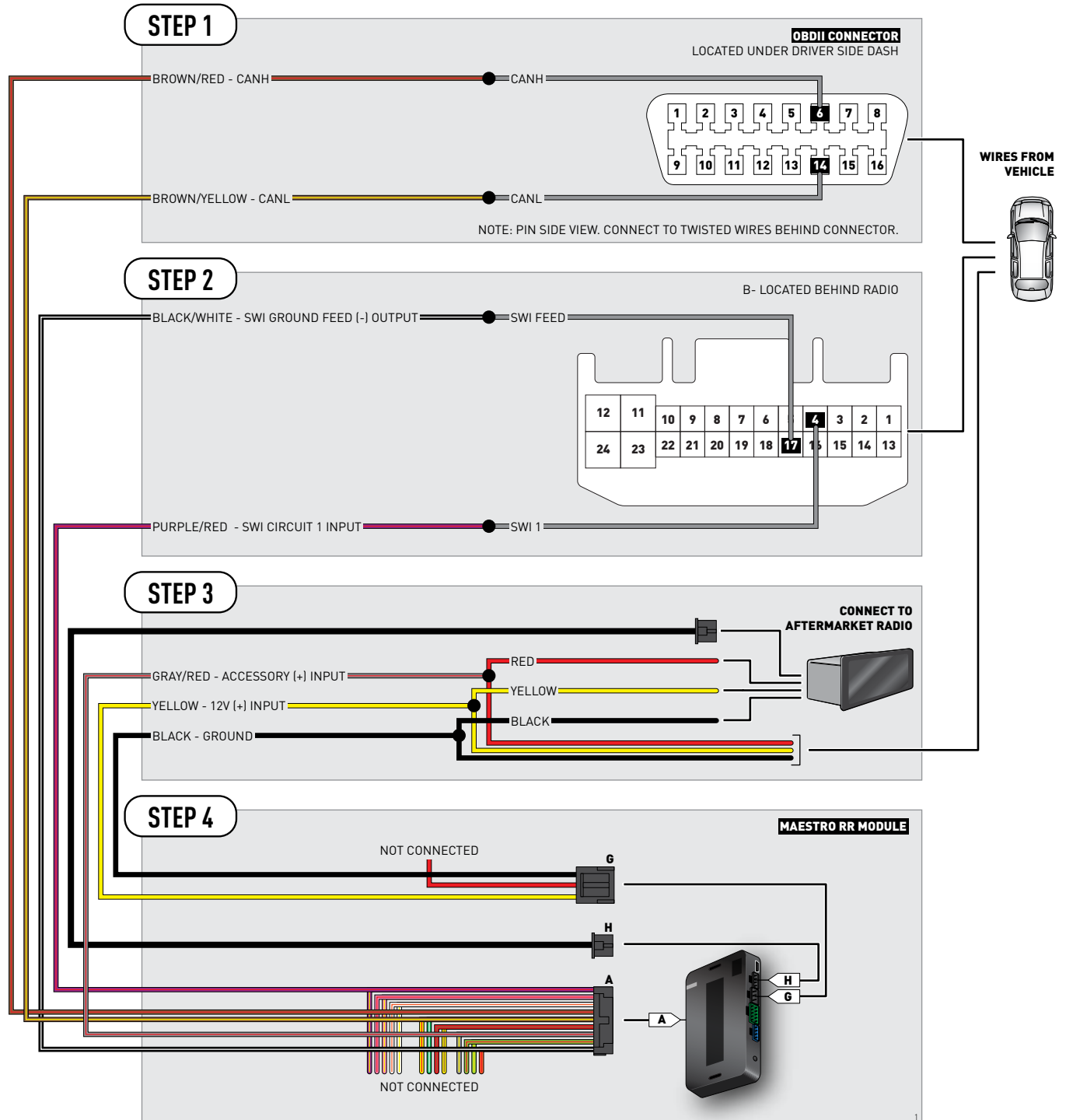

VEHICLE WIRE REFERENCE CHART

Wire Description	Connector Name	Connector Color	Connector Type	Position	Wire Color	Polarity	Wire Location
CanH	A	~	16 pin	06	Green	(DATA)	OBDII connector, under driver side dash
CanL	A	~	16 pin	14	Orange	(DATA)	OBDII connector, under driver side dash
SWI 1	B	~	24 pin	04	Blue	(DATA)	Behind radio
SWI Feed	B	~	24 pin	17	Gray	(-)	Behind radio



INSTALL GUIDE HYUNDAI VELOSTER BASE 2012-2014

RETAINS STEERING WHEEL CONTROLS AND ADDS GAUGES



PRODUCTS REQUIRED

iDatalink Maestro RR Radio Replacement Interface
iDatalink Compatible Radio

OPTIONAL ACCESSORIES

None

PROGRAMMED FIRMWARE

ADS-RR(SI)-HYU01-DS

NOTICE: Automotive Data Solutions Inc. (ADS) recommends having this installation performed by a certified technician. Logos and trademarks used here in are the properties of their respective owners.

WELCOME

Congratulations on the purchase of your iDatalink Maestro RR Radio replacement solution. You are now a few simple steps away from enjoying your new car radio with enhanced features.

Before starting your installation, please ensure that your iDatalink Maestro module is programmed with the correct firmware for your vehicle and that you carefully review the install guide.

Please note that Maestro RR will only retain functionalities that were originally available in the vehicle.

NEED HELP?

 **1 866 427-2999**

 **support@idatalink.com**

 **maestro.idatalink.com/support
www.12voltdata.com/forum**

TABLE OF CONTENTS

Wiring Diagram	3
Vehicle Wire Reference Chart	4

WIRING DIAGRAM

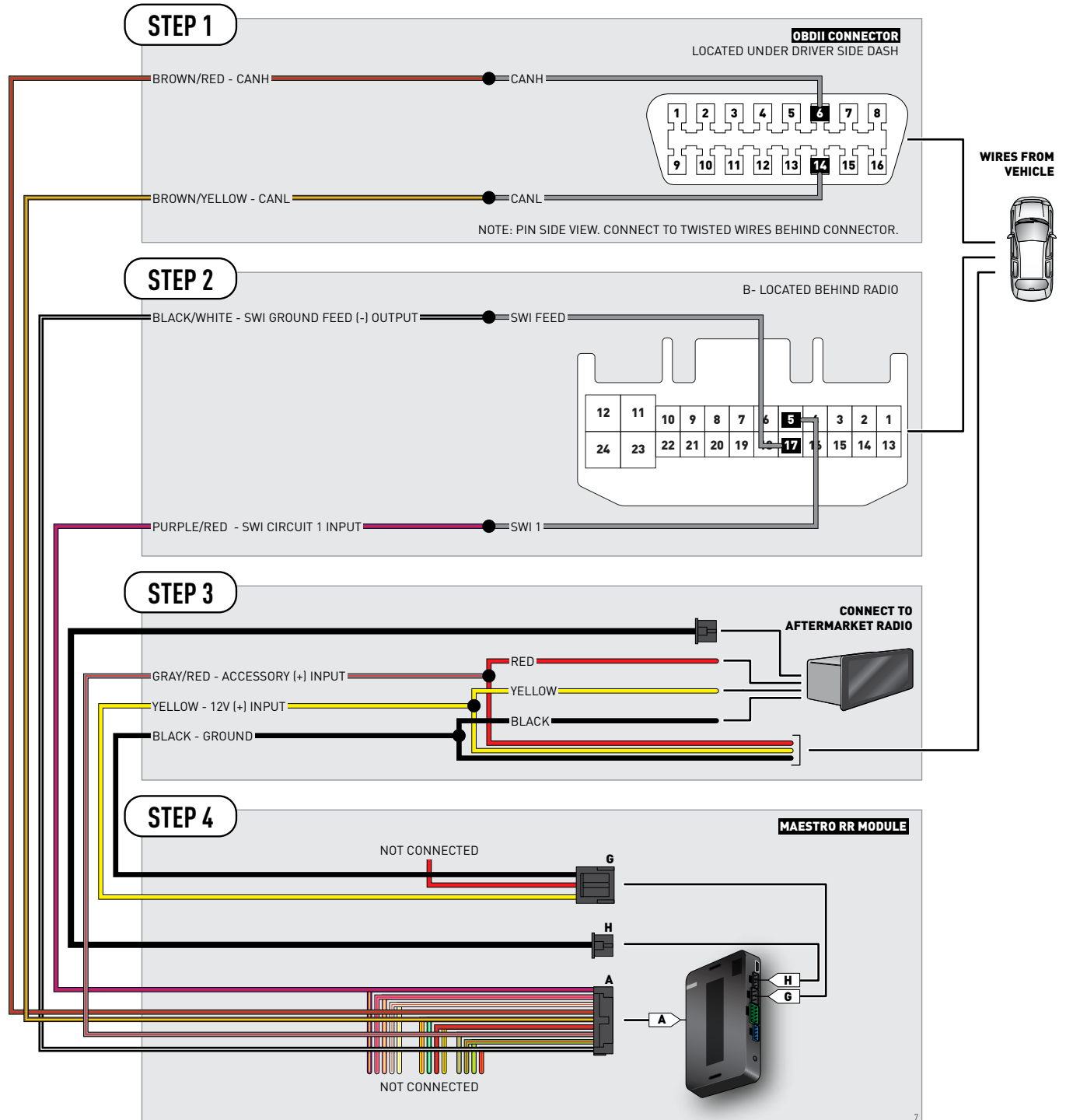

VEHICLE WIRE REFERENCE CHART

Wire Description	Connector Name	Connector Color	Connector Type	Position	Wire Color	Polarity	Wire Location
CanH	A	~	16 pin	06	White	[DATA]	OBDII connector, under driver side dash
CanL	A	~	16 pin	14	Yellow	[DATA]	OBDII connector, under driver side dash
SWI 1	B	~	24 pin	05	Gray	[DATA]	Behind radio
SWI Feed	B	~	24 pin	17	Green	(-)	Behind radio



INSTALL GUIDE HYUNDAI VERACRUZ BASE 2007-2008

RETAINS STEERING WHEEL CONTROLS AND ADDS GAUGES



PRODUCTS REQUIRED

iDatalink Maestro RR Radio Replacement Interface
iDatalink Compatible Radio

OPTIONAL ACCESSORIES

None

PROGRAMMED FIRMWARE

ADS-RR(SI)-HYU01-DS

NOTICE: Automotive Data Solutions Inc. (ADS) recommends having this installation performed by a certified technician. Logos and trademarks used here in are the properties of their respective owners.

WELCOME

Congratulations on the purchase of your iDatalink Maestro RR Radio replacement solution. You are now a few simple steps away from enjoying your new car radio with enhanced features.

Before starting your installation, please ensure that your iDatalink Maestro module is programmed with the correct firmware for your vehicle and that you carefully review the install guide.

Please note that Maestro RR will only retain functionalities that were originally available in the vehicle.

NEED HELP?

 **1 866 427-2999**

 support@idatalink.com

 maestro.idatalink.com/support
www.12voltdata.com/forum

TABLE OF CONTENTS

Wiring Diagram	3
Vehicle Wire Reference Chart	4

WIRING DIAGRAM

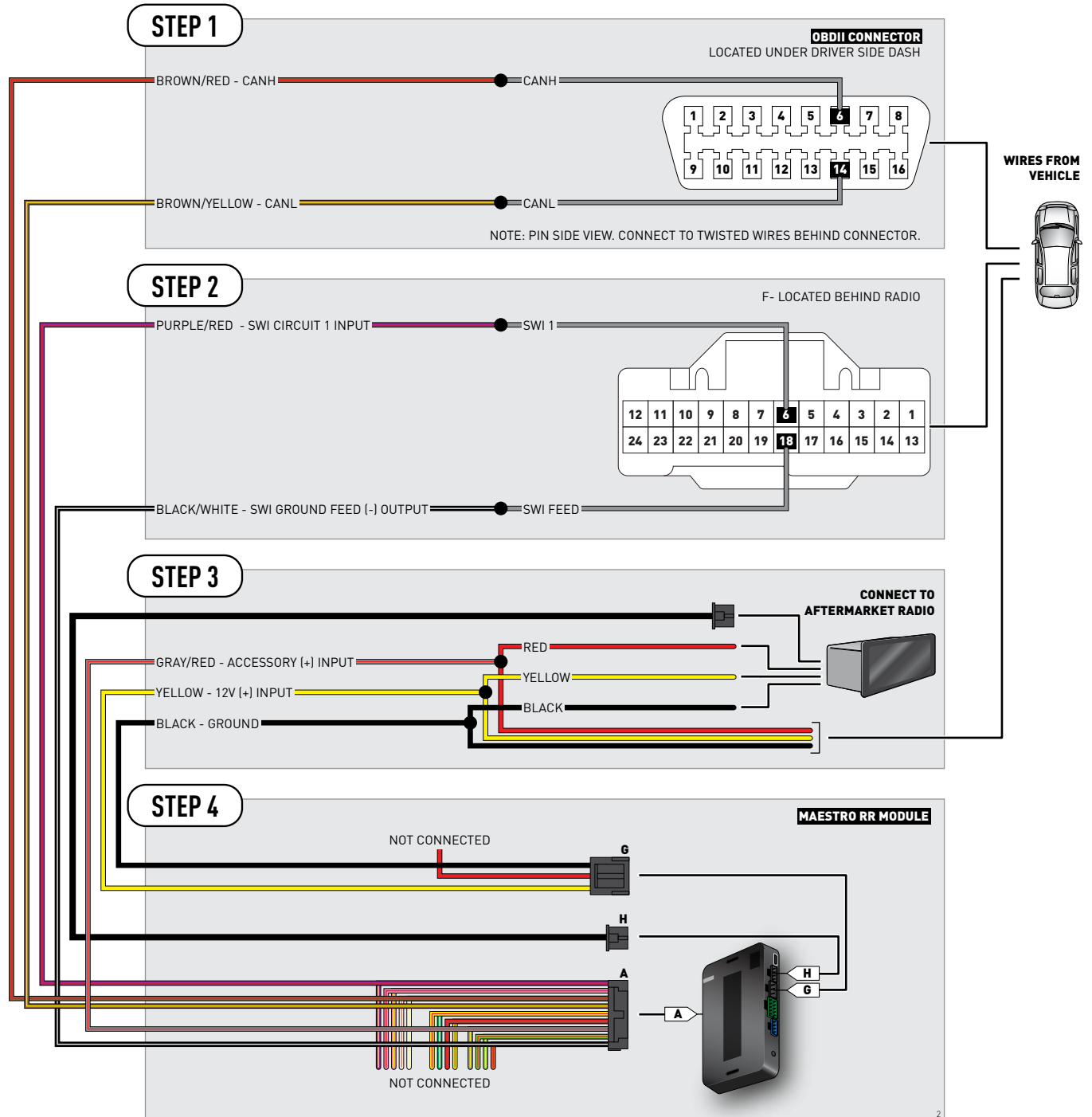

VEHICLE WIRE REFERENCE CHART

Wire Description	Connector Name	Connector Color	Connector Type	Position	Wire Color	Polarity	Wire Location
CanH	A	~	16 pin	06	Orange	(DATA)	OBDII connector, under driver side dash
CanL	A	~	16 pin	14	Blue	(DATA)	OBDII connector, under driver side dash
SWI 1	F	~	24 pin	06	Blue	(DATA)	Behind radio
SWI Feed	F	~	24 pin	18	Blue/Black	(-)	Behind radio



INSTALL GUIDE HYUNDAI VERACRUZ BASE 2009-2013

RETAINS STEERING WHEEL CONTROLS AND ADDS GAUGES



PRODUCTS REQUIRED

iDatalink Maestro RR Radio Replacement Interface
iDatalink Compatible Radio

OPTIONAL ACCESSORIES

None

PROGRAMMED FIRMWARE

ADS-RR(SI)-HYU01-DS

NOTICE: Automotive Data Solutions Inc. (ADS) recommends having this installation performed by a certified technician. Logos and trademarks used here in are the properties of their respective owners.

WELCOME

Congratulations on the purchase of your iDatalink Maestro RR Radio replacement solution. You are now a few simple steps away from enjoying your new car radio with enhanced features.

Before starting your installation, please ensure that your iDatalink Maestro module is programmed with the correct firmware for your vehicle and that you carefully review the install guide.

Please note that Maestro RR will only retain functionalities that were originally available in the vehicle.

NEED HELP?

 **1 866 427-2999**

 support@idatalink.com

 maestro.idatalink.com/support
www.12voltdata.com/forum

TABLE OF CONTENTS

Wiring Diagram	3
Vehicle Wire Reference Chart	4

WIRING DIAGRAM

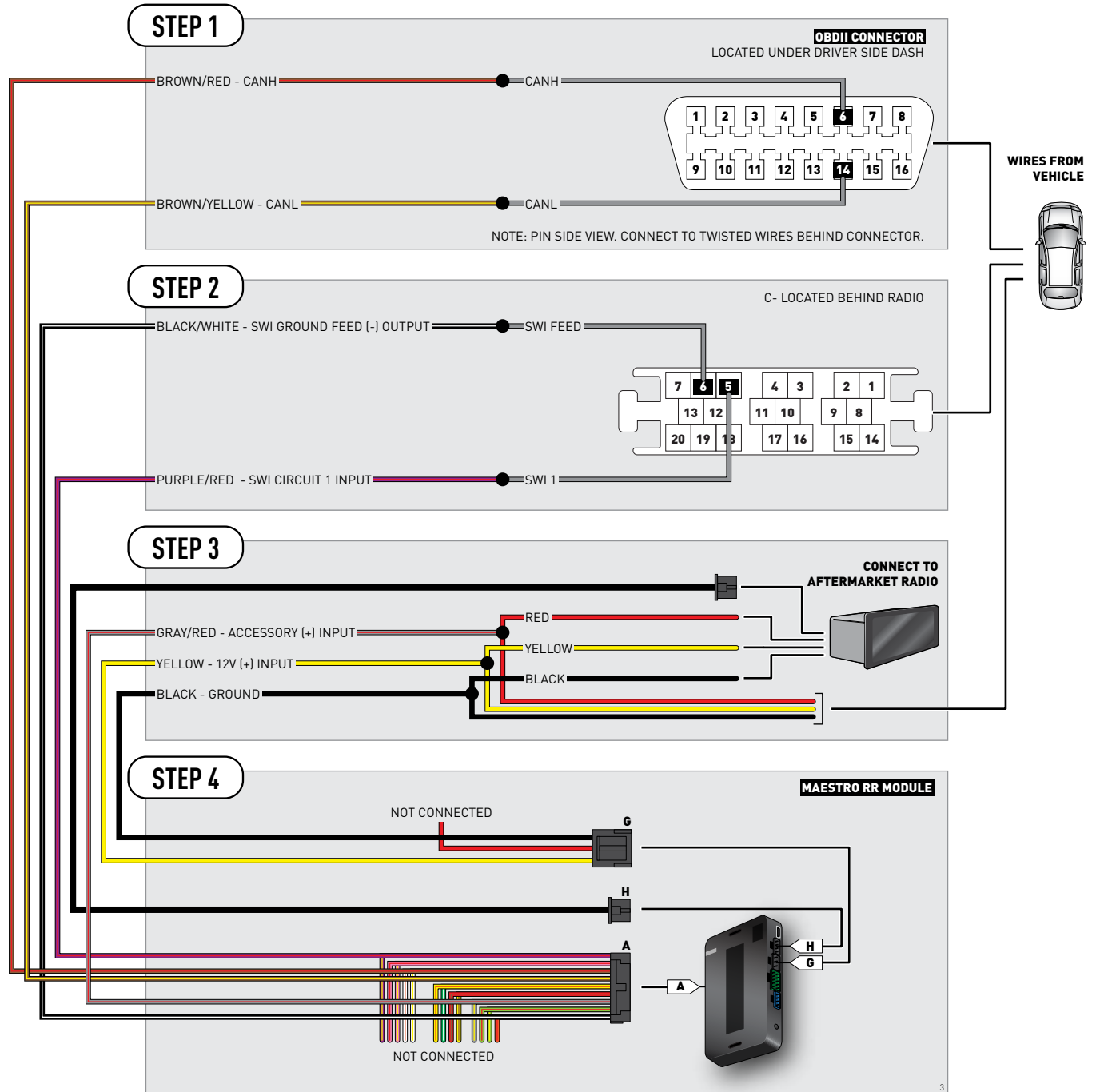

VEHICLE WIRE REFERENCE CHART

Wire Description	Connector Name	Connector Color	Connector Type	Position	Wire Color	Polarity	Wire Location
CanH	A	~	16 pin	06	Orange	(DATA)	OBDII connector, under driver side dash
CanL	A	~	16 pin	14	Blue	(DATA)	OBDII connector, under driver side dash
SWI 1	C	~	20 pin	05	Blue	(DATA)	Behind radio
SWI Feed	C	~	20 pin	06	Blue/Black	(-)	Behind radio



INSTALL GUIDE KIA AMANTI BASE 2007-2009

RETAINS STEERING WHEEL CONTROLS AND ADDS GAUGES



PRODUCTS REQUIRED

iDatalink Maestro RR Radio Replacement Interface
iDatalink Compatible Radio

OPTIONAL ACCESSORIES

None

PROGRAMMED FIRMWARE

ADS-RR(SI)-HYU01-DS

NOTICE: Automotive Data Solutions Inc. (ADS) recommends having this installation performed by a certified technician. Logos and trademarks used here in are the properties of their respective owners.

WELCOME

Congratulations on the purchase of your iDatalink Maestro RR Radio replacement solution. You are now a few simple steps away from enjoying your new car radio with enhanced features.

Before starting your installation, please ensure that your iDatalink Maestro module is programmed with the correct firmware for your vehicle and that you carefully review the install guide.

Please note that Maestro RR will only retain functionalities that were originally available in the vehicle.

NEED HELP?

 **1 866 427-2999**

 support@idatalink.com

 maestro.idatalink.com/support
www.12voltdata.com/forum

TABLE OF CONTENTS

Wiring Diagram	3
Vehicle Wire Reference Chart	4

WIRING DIAGRAM

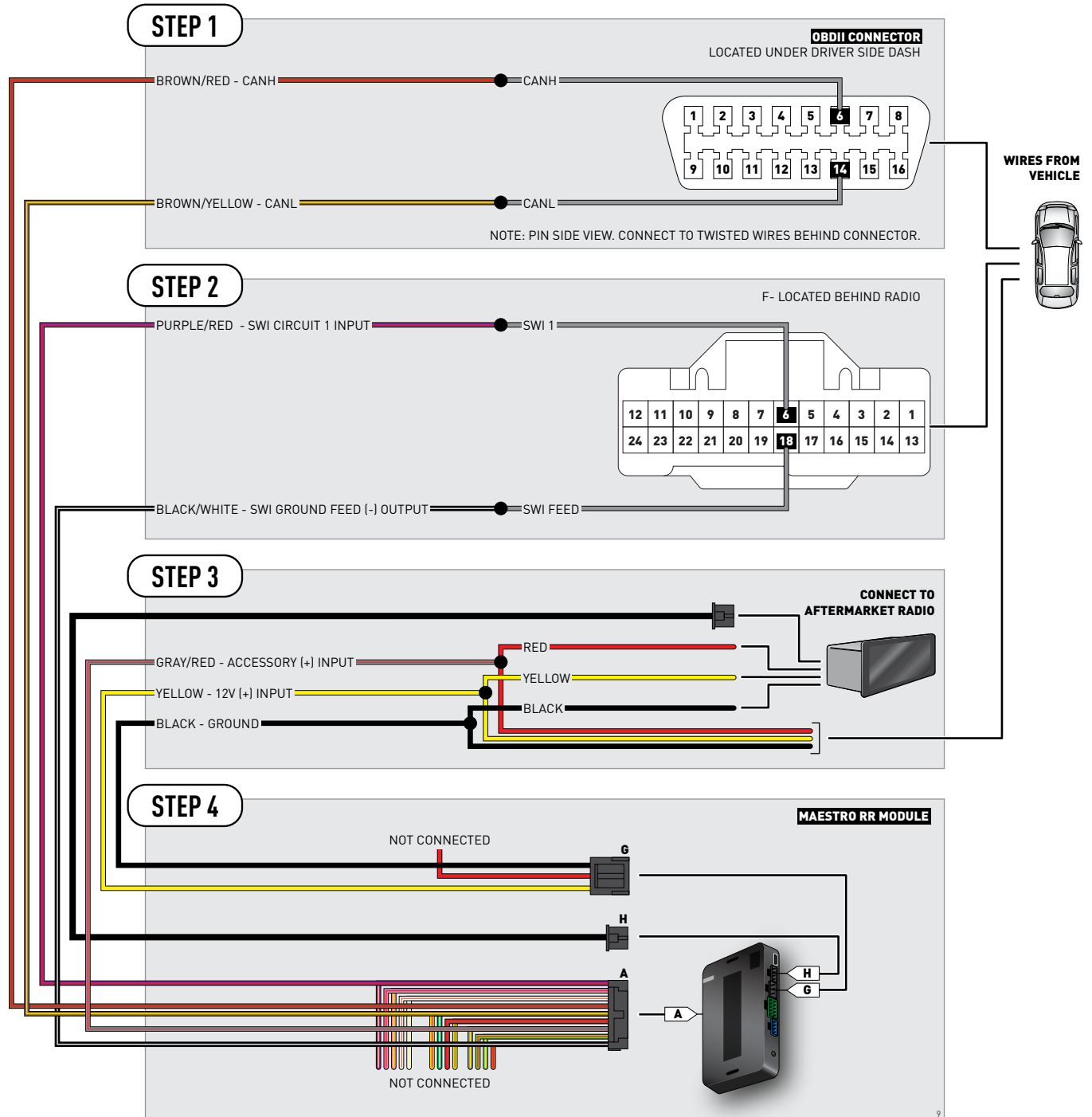

VEHICLE WIRE REFERENCE CHART

Wire Description	Connector Name	Connector Color	Connector Type	Position	Wire Color	Polarity	Wire Location
CanH	A	~	16 pin	06	Green	[DATA]	OBDII connector, under driver side dash
CanL	A	~	16 pin	14	Orange	[DATA]	OBDII connector, under driver side dash
SWI 1	F	~	24 pin	06	Pink	[DATA]	Behind radio
SWI Feed	F	~	24 pin	18	Brown/Orange	(-)	Behind radio



INSTALL GUIDE KIA AMANTI JBL 2007-2010

RETAINS STEERING WHEEL CONTROLS AND ADDS GAUGES



PRODUCTS REQUIRED

iDatalink Maestro RR Radio Replacement Interface
iDatalink Compatible Radio

OPTIONAL ACCESSORIES

None

PROGRAMMED FIRMWARE

ADS-RR(SI)-HYU01-DS

NOTICE: Automotive Data Solutions Inc. (ADS) recommends having this installation performed by a certified technician. Logos and trademarks used here in are the properties of their respective owners.

WELCOME

Congratulations on the purchase of your iDatalink Maestro RR Radio replacement solution. You are now a few simple steps away from enjoying your new car radio with enhanced features.

Before starting your installation, please ensure that your iDatalink Maestro module is programmed with the correct firmware for your vehicle and that you carefully review the install guide.

Please note that Maestro RR will only retain functionalities that were originally available in the vehicle.

NEED HELP?

 **1 866 427-2999**

 support@idatalink.com

 maestro.idatalink.com/support
www.12voltdata.com/forum

TABLE OF CONTENTS

Wiring Diagram	3
Vehicle Wire Reference Chart	4

WIRING DIAGRAM

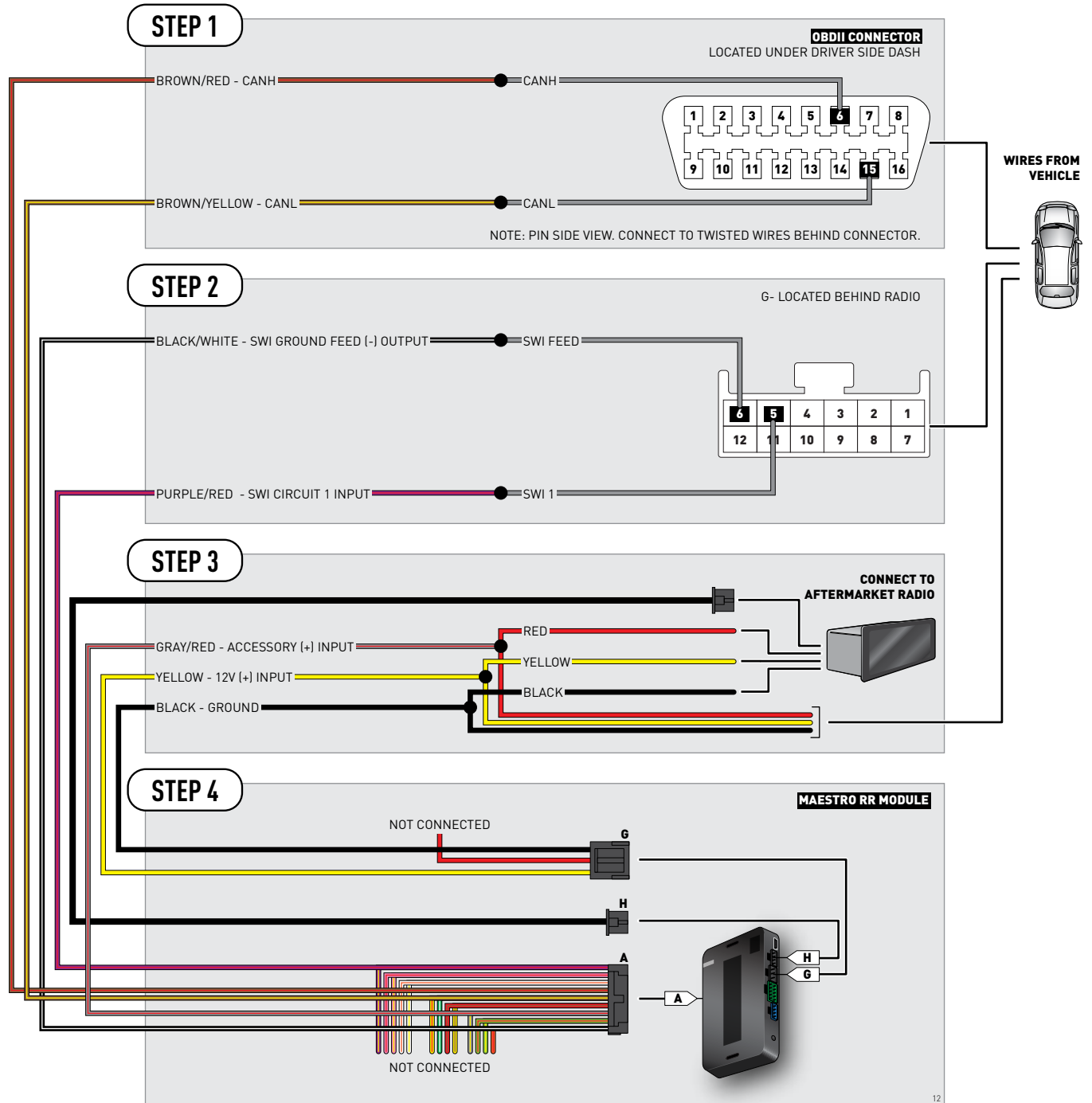

12

VEHICLE WIRE REFERENCE CHART

Wire Description	Connector Name	Connector Color	Connector Type	Position	Wire Color	Polarity	Wire Location
CanH	A	~	16 pin	06	Green	[DATA]	OBDII connector, under driver side dash
CanL	A	~	16 pin	15	Orange	[DATA]	OBDII connector, under driver side dash
SWI 1	G	~	12 pin	05	Yellow/Black	[DATA]	Behind radio
SWI Feed	G	~	12 pin	06	Brown	(-)	Behind radio



INSTALL GUIDE KIA BORREGO BASE 2008-2009

RETAINS STEERING WHEEL CONTROLS AND ADDS GAUGES



PRODUCTS REQUIRED

iDatalink Maestro RR Radio Replacement Interface
iDatalink Compatible Radio

OPTIONAL ACCESSORIES

None

PROGRAMMED FIRMWARE

ADS-RR(SI)-HYU01-DS

NOTICE: Automotive Data Solutions Inc. (ADS) recommends having this installation performed by a certified technician. Logos and trademarks used here in are the properties of their respective owners.

WELCOME

Congratulations on the purchase of your iDatalink Maestro RR Radio replacement solution. You are now a few simple steps away from enjoying your new car radio with enhanced features.

Before starting your installation, please ensure that your iDatalink Maestro module is programmed with the correct firmware for your vehicle and that you carefully review the install guide.

Please note that Maestro RR will only retain functionalities that were originally available in the vehicle.

NEED HELP?

 **1 866 427-2999**

 support@idatalink.com

 maestro.idatalink.com/support
www.12voltdata.com/forum

TABLE OF CONTENTS

Wiring Diagram	3
Vehicle Wire Reference Chart	4

WIRING DIAGRAM

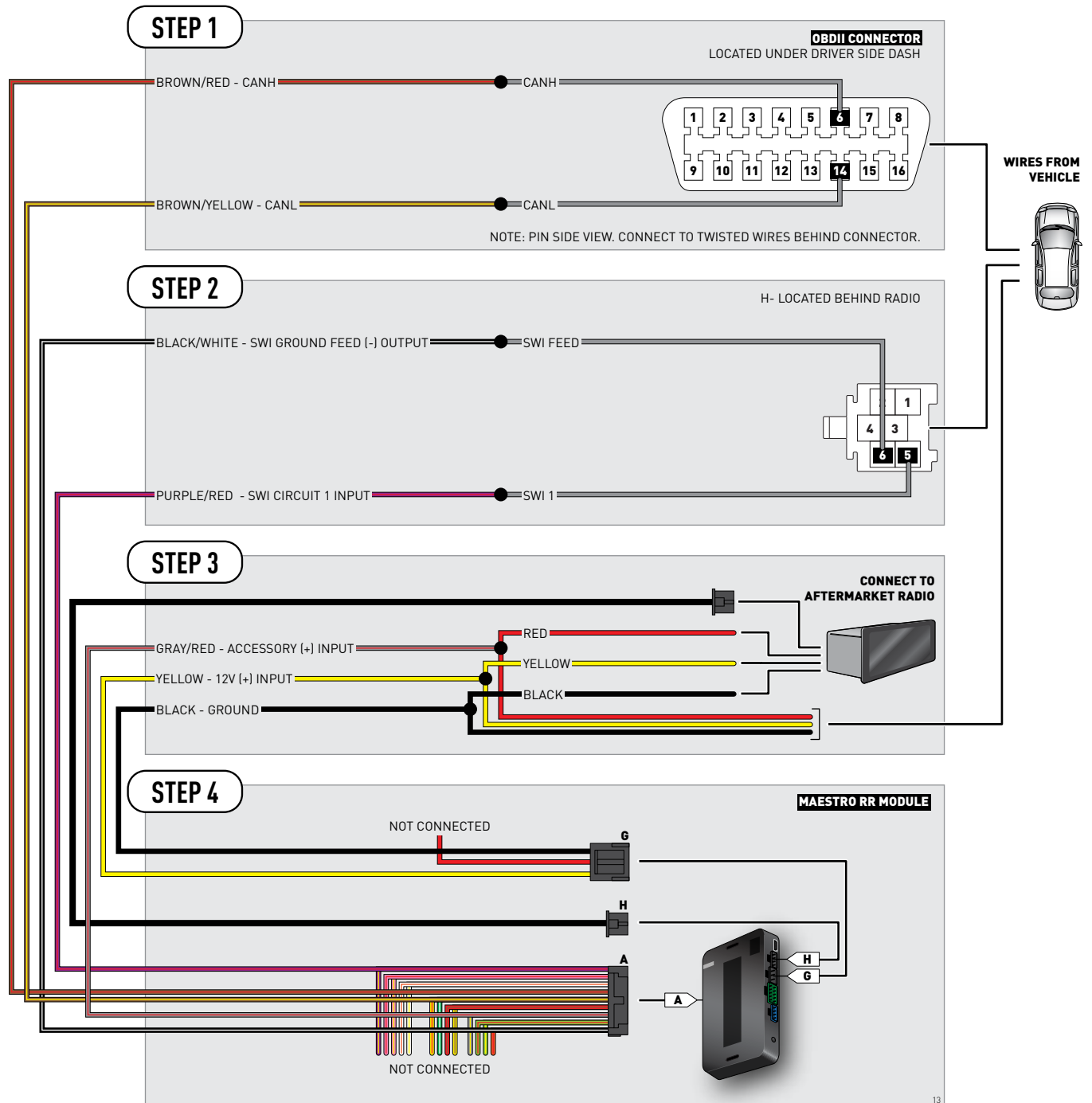

13

VEHICLE WIRE REFERENCE CHART

Wire Description	Connector Name	Connector Color	Connector Type	Position	Wire Color	Polarity	Wire Location
CanH	A	~	16 pin	06	Black	(DATA)	OBDII connector, under driver side dash
CanL	A	~	16 pin	14	White	(DATA)	OBDII connector, under driver side dash
SWI 1	H	~	06 pin	05	Blue/Black	(DATA)	Behind radio
SWI Feed	H	~	06 pin	06	Red	(-)	Behind radio



INSTALL GUIDE KIA FORTE BASE 2010-2013

RETAINS STEERING WHEEL CONTROLS AND ADDS GAUGES



PRODUCTS REQUIRED

iDatalink Maestro RR Radio Replacement Interface
iDatalink Compatible Radio

OPTIONAL ACCESSORIES

None

PROGRAMMED FIRMWARE

ADS-RR(SI)-HYU01-DS

NOTICE: Automotive Data Solutions Inc. (ADS) recommends having this installation performed by a certified technician. Logos and trademarks used here in are the properties of their respective owners.

WELCOME

Congratulations on the purchase of your iDatalink Maestro RR Radio replacement solution. You are now a few simple steps away from enjoying your new car radio with enhanced features.

Before starting your installation, please ensure that your iDatalink Maestro module is programmed with the correct firmware for your vehicle and that you carefully review the install guide.

Please note that Maestro RR will only retain functionalities that were originally available in the vehicle.

NEED HELP?

 **1 866 427-2999**

 **support@idatalink.com**

 **maestro.idatalink.com/support
www.12voltdata.com/forum**

TABLE OF CONTENTS

Wiring Diagram	3
Vehicle Wire Reference Chart	4

WIRING DIAGRAM

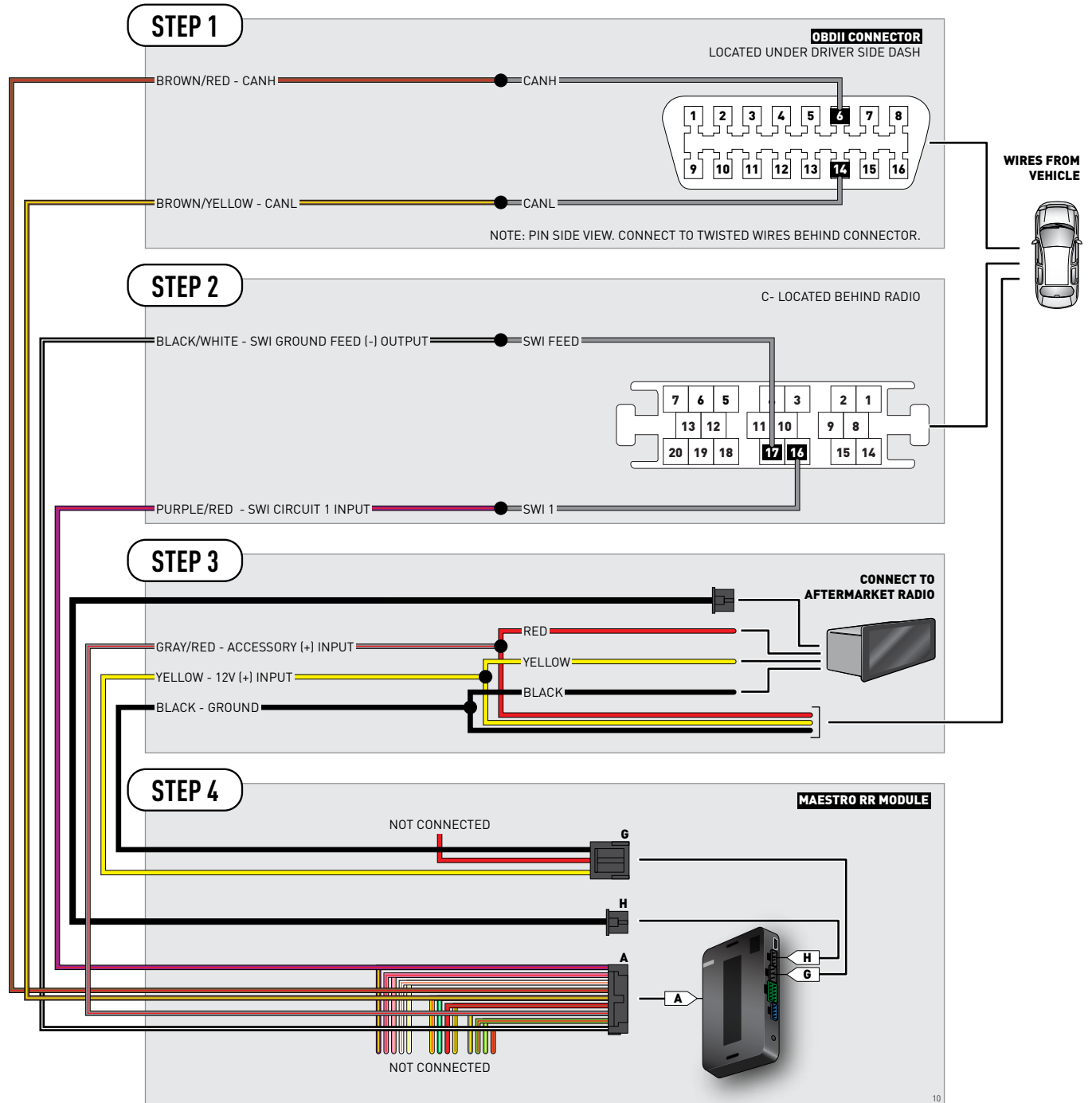

VEHICLE WIRE REFERENCE CHART

Wire Description	Connector Name	Connector Color	Connector Type	Position	Wire Color	Polarity	Wire Location
CanH	A	~	16 pin	06	Black	[DATA]	OBDII connector, under driver side dash
CanL	A	~	16 pin	14	White	[DATA]	OBDII connector, under driver side dash
SWI 1	C	~	20 pin	16	Green	[DATA]	Behind radio
SWI Feed	C	~	20 pin	17	Brown/Black	(-)	Behind radio



INSTALL GUIDE KIA FORTE BASE 2014

RETAINS STEERING WHEEL CONTROLS AND ADDS GAUGES



PRODUCTS REQUIRED

iDatalink Maestro RR Radio Replacement Interface
iDatalink Compatible Radio

OPTIONAL ACCESSORIES

None

PROGRAMMED FIRMWARE

ADS-RR(SI)-HYU01-DS

NOTICE: Automotive Data Solutions Inc. (ADS) recommends having this installation performed by a certified technician. Logos and trademarks used here in are the properties of their respective owners.

WELCOME

Congratulations on the purchase of your iDatalink Maestro RR Radio replacement solution. You are now a few simple steps away from enjoying your new car radio with enhanced features.

Before starting your installation, please ensure that your iDatalink Maestro module is programmed with the correct firmware for your vehicle and that you carefully review the install guide.

Please note that Maestro RR will only retain functionalities that were originally available in the vehicle.

NEED HELP?

 **1 866 427-2999**

 support@idatalink.com

 maestro.idatalink.com/support
www.12voltdata.com/forum

TABLE OF CONTENTS

Wiring Diagram	3
Vehicle Wire Reference Chart	4

WIRING DIAGRAM

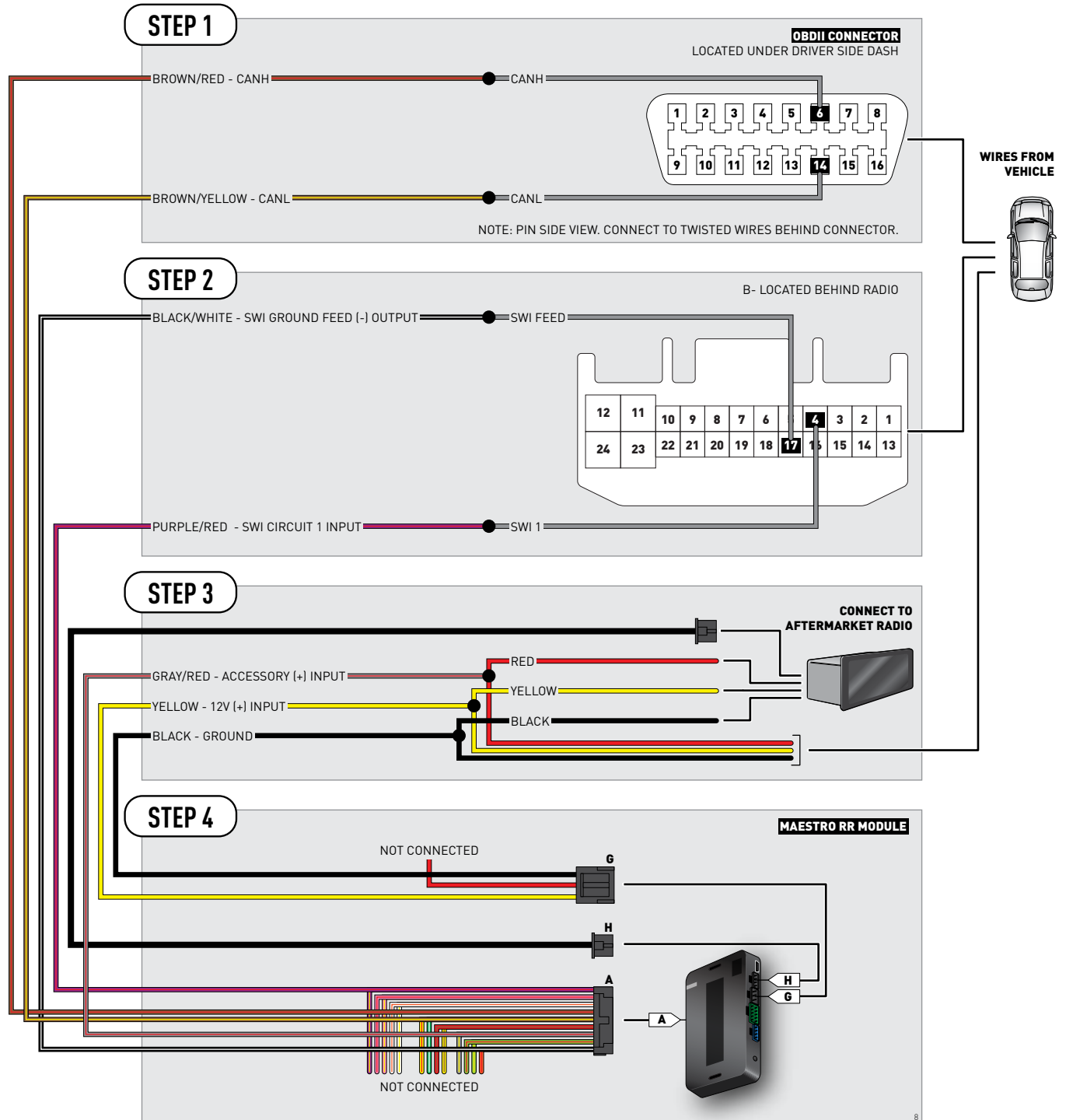

VEHICLE WIRE REFERENCE CHART

Wire Description	Connector Name	Connector Color	Connector Type	Position	Wire Color	Polarity	Wire Location
CanH	A	~	16 pin	06	White	[DATA]	OBDII connector, under driver side dash
CanL	A	~	16 pin	14	Brown	[DATA]	OBDII connector, under driver side dash
SWI 1	B	~	24 pin	04	Brown	[DATA]	Behind radio
SWI Feed	B	~	24 pin	17	Green	(-)	Behind radio



INSTALL GUIDE KIA FORTE KOUP BASE 2010-2013

RETAINS STEERING WHEEL CONTROLS AND ADDS GAUGES



PRODUCTS REQUIRED

iDatalink Maestro RR Radio Replacement Interface
iDatalink Compatible Radio

OPTIONAL ACCESSORIES

None

PROGRAMMED FIRMWARE

ADS-RR(SI)-HYU01-DS

NOTICE: Automotive Data Solutions Inc. (ADS) recommends having this installation performed by a certified technician. Logos and trademarks used here in are the properties of their respective owners.

WELCOME

Congratulations on the purchase of your iDatalink Maestro RR Radio replacement solution. You are now a few simple steps away from enjoying your new car radio with enhanced features.

Before starting your installation, please ensure that your iDatalink Maestro module is programmed with the correct firmware for your vehicle and that you carefully review the install guide.

Please note that Maestro RR will only retain functionalities that were originally available in the vehicle.

NEED HELP?

 **1 866 427-2999**

 support@idatalink.com

 maestro.idatalink.com/support
www.12voltdata.com/forum

TABLE OF CONTENTS

Wiring Diagram	3
Vehicle Wire Reference Chart	4

WIRING DIAGRAM

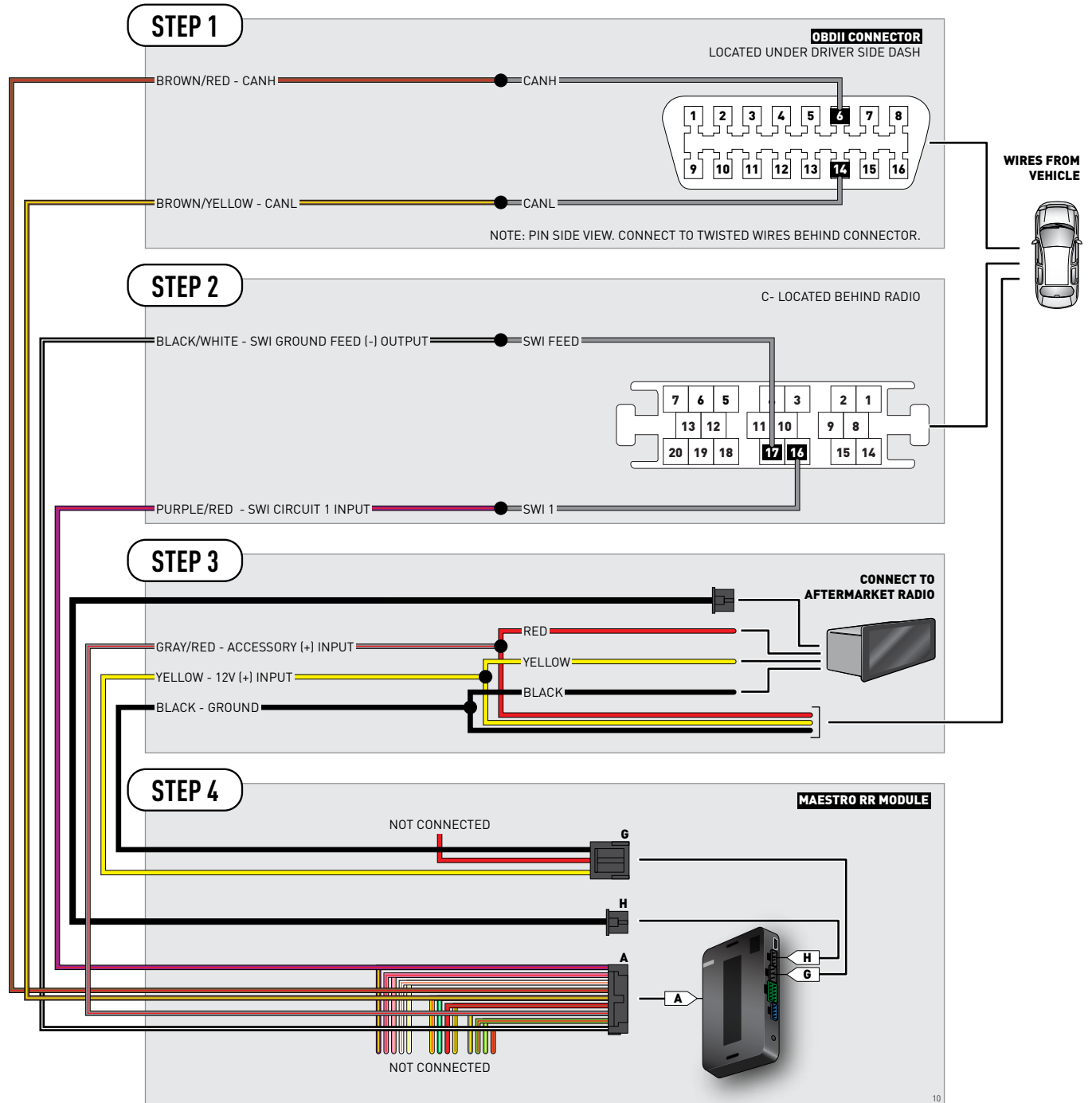

VEHICLE WIRE REFERENCE CHART

Wire Description	Connector Name	Connector Color	Connector Type	Position	Wire Color	Polarity	Wire Location
CanH	A	~	16 pin	06	Black	(DATA)	OBDII connector, under driver side dash
CanL	A	~	16 pin	14	White	(DATA)	OBDII connector, under driver side dash
SWI 1	C	~	20 pin	16	Green	(DATA)	Behind radio
SWI Feed	C	~	20 pin	17	Brown/Black	(-)	Behind radio



INSTALL GUIDE KIA FORTE KOUP BASE 2014

RETAINS STEERING WHEEL CONTROLS AND ADDS GAUGES



PRODUCTS REQUIRED

iDatalink Maestro RR Radio Replacement Interface
iDatalink Compatible Radio

OPTIONAL ACCESSORIES

None

PROGRAMMED FIRMWARE

ADS-RR(SI)-HYU01-DS

NOTICE: Automotive Data Solutions Inc. (ADS) recommends having this installation performed by a certified technician. Logos and trademarks used here in are the properties of their respective owners.

WELCOME

Congratulations on the purchase of your iDatalink Maestro RR Radio replacement solution. You are now a few simple steps away from enjoying your new car radio with enhanced features.

Before starting your installation, please ensure that your iDatalink Maestro module is programmed with the correct firmware for your vehicle and that you carefully review the install guide.

Please note that Maestro RR will only retain functionalities that were originally available in the vehicle.

NEED HELP?

 **1 866 427-2999**

 support@idatalink.com

 maestro.idatalink.com/support
www.12voltdata.com/forum

TABLE OF CONTENTS

Wiring Diagram	3
Vehicle Wire Reference Chart	4

WIRING DIAGRAM

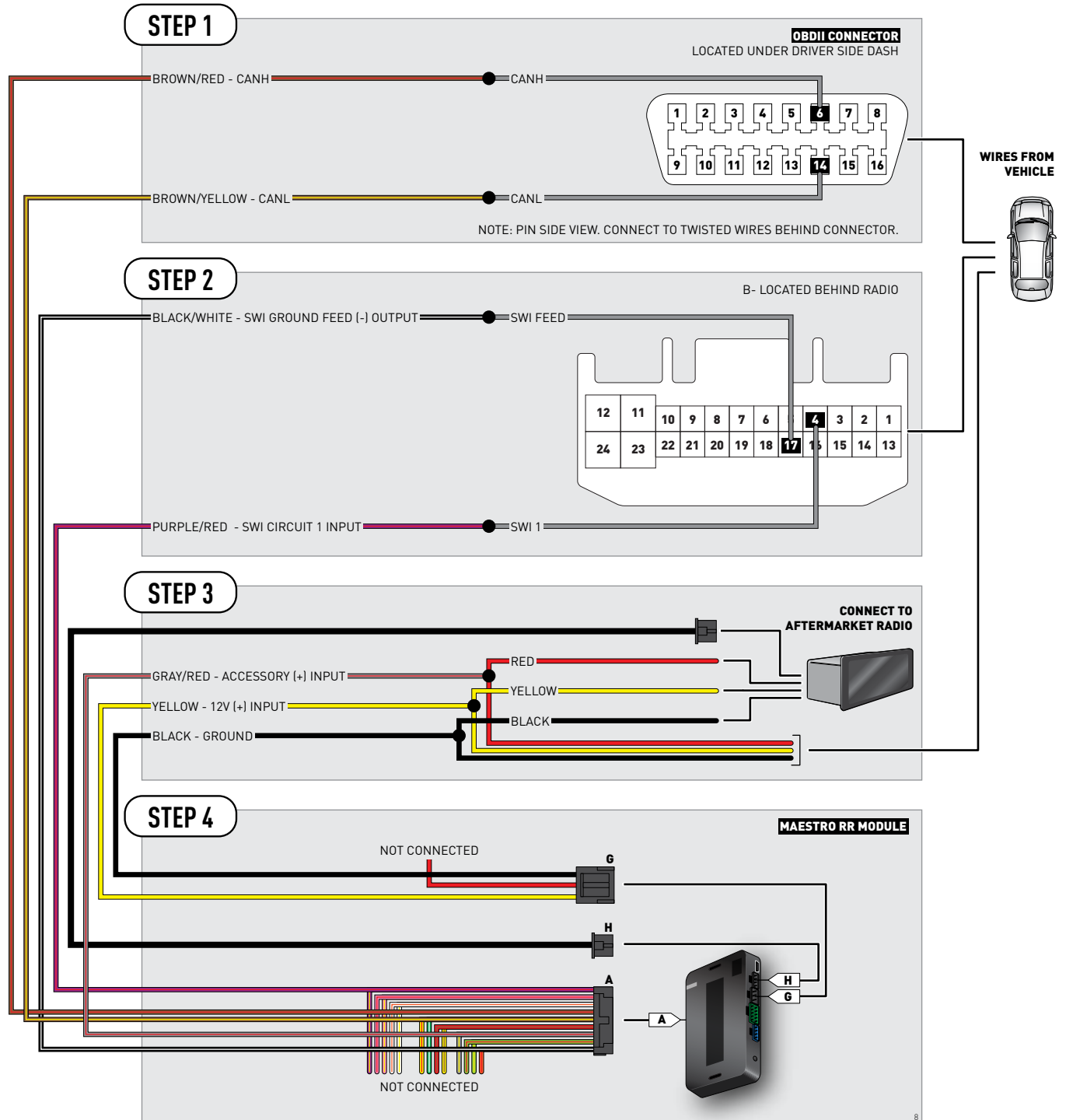

VEHICLE WIRE REFERENCE CHART

Wire Description	Connector Name	Connector Color	Connector Type	Position	Wire Color	Polarity	Wire Location
CanH	A	~	16 pin	06	White	[DATA]	OBDII connector, under driver side dash
CanL	A	~	16 pin	14	Brown	[DATA]	OBDII connector, under driver side dash
SWI 1	B	~	24 pin	04	Brown	[DATA]	Behind radio
SWI Feed	B	~	24 pin	17	Green	(-)	Behind radio



INSTALL GUIDE KIA OPTIMA BASE 2006-2010

RETAINS STEERING WHEEL CONTROLS AND ADDS GAUGES



PRODUCTS REQUIRED

iDatalink Maestro RR Radio Replacement Interface
iDatalink Compatible Radio

OPTIONAL ACCESSORIES

None

PROGRAMMED FIRMWARE

ADS-RR(SI)-HYU01-DS

NOTICE: Automotive Data Solutions Inc. (ADS) recommends having this installation performed by a certified technician. Logos and trademarks used here in are the properties of their respective owners.

WELCOME

Congratulations on the purchase of your iDatalink Maestro RR Radio replacement solution. You are now a few simple steps away from enjoying your new car radio with enhanced features.

Before starting your installation, please ensure that your iDatalink Maestro module is programmed with the correct firmware for your vehicle and that you carefully review the install guide.

Please note that Maestro RR will only retain functionalities that were originally available in the vehicle.

NEED HELP?

 **1 866 427-2999**

 support@idatalink.com

 maestro.idatalink.com/support
www.12voltdata.com/forum

TABLE OF CONTENTS

Wiring Diagram	3
Vehicle Wire Reference Chart	4

WIRING DIAGRAM

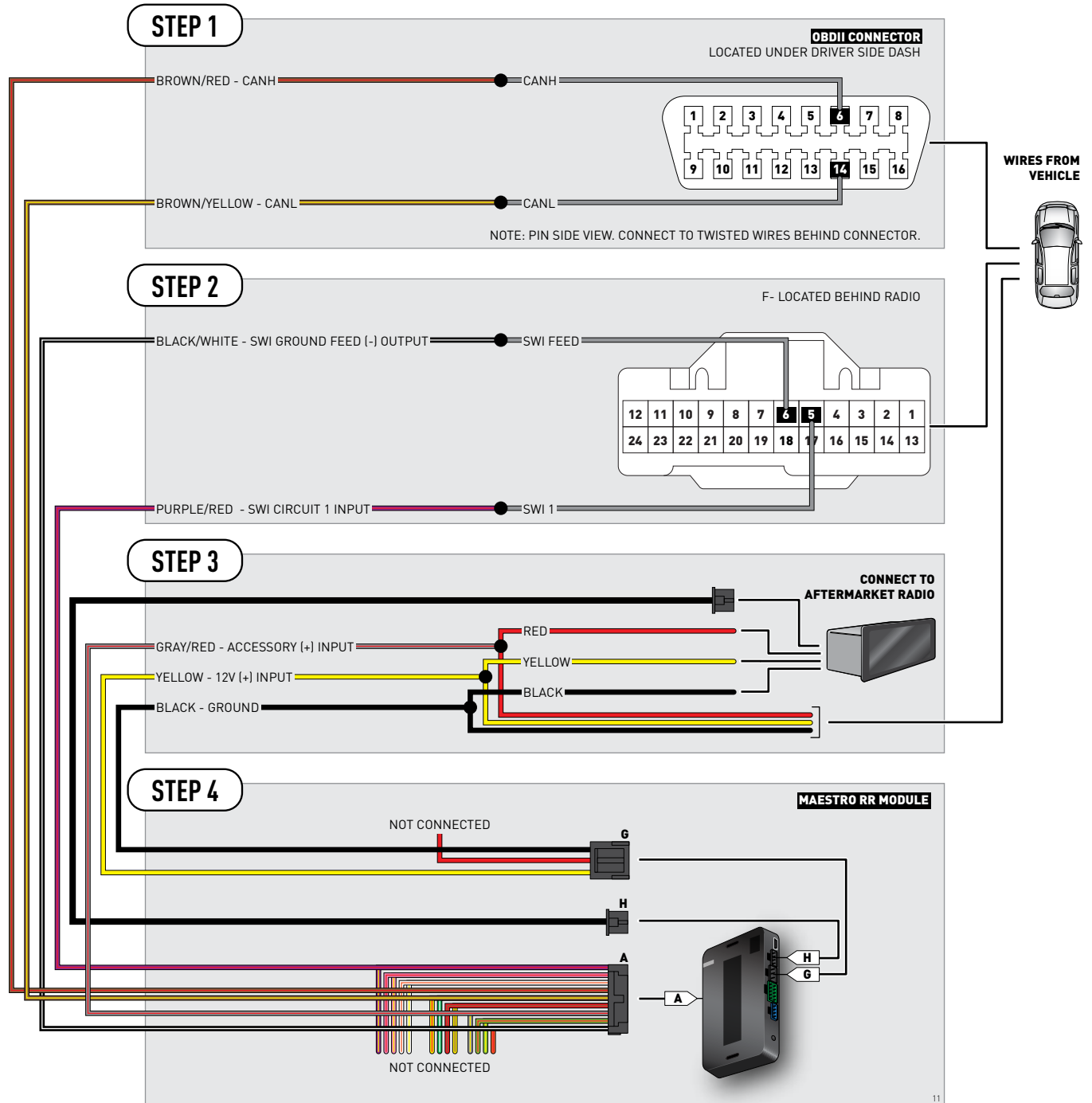

VEHICLE WIRE REFERENCE CHART

Wire Description	Connector Name	Connector Color	Connector Type	Position	Wire Color	Polarity	Wire Location
CanH	A	~	16 pin	06	White	[DATA]	OBDII connector, under driver side dash
CanL	A	~	16 pin	14	Black	[DATA]	OBDII connector, under driver side dash
SWI 1	F	~	24 pin	05	Brown	[DATA]	Behind radio
SWI Feed	F	~	24 pin	06	Green	(-)	Behind radio



INSTALL GUIDE KIA OPTIMA BASE 2011-2014

RETAINS STEERING WHEEL CONTROLS AND ADDS GAUGES



PRODUCTS REQUIRED

iDatalink Maestro RR Radio Replacement Interface
iDatalink Compatible Radio

OPTIONAL ACCESSORIES

None

PROGRAMMED FIRMWARE

ADS-RR(SI)-HYU01-DS

NOTICE: Automotive Data Solutions Inc. (ADS) recommends having this installation performed by a certified technician. Logos and trademarks used here in are the properties of their respective owners.

WELCOME

Congratulations on the purchase of your iDatalink Maestro RR Radio replacement solution. You are now a few simple steps away from enjoying your new car radio with enhanced features.

Before starting your installation, please ensure that your iDatalink Maestro module is programmed with the correct firmware for your vehicle and that you carefully review the install guide.

Please note that Maestro RR will only retain functionalities that were originally available in the vehicle.

NEED HELP?

 **1 866 427-2999**

 support@idatalink.com

 maestro.idatalink.com/support
www.12voltdata.com/forum

TABLE OF CONTENTS

Wiring Diagram	3
Vehicle Wire Reference Chart	4

WIRING DIAGRAM

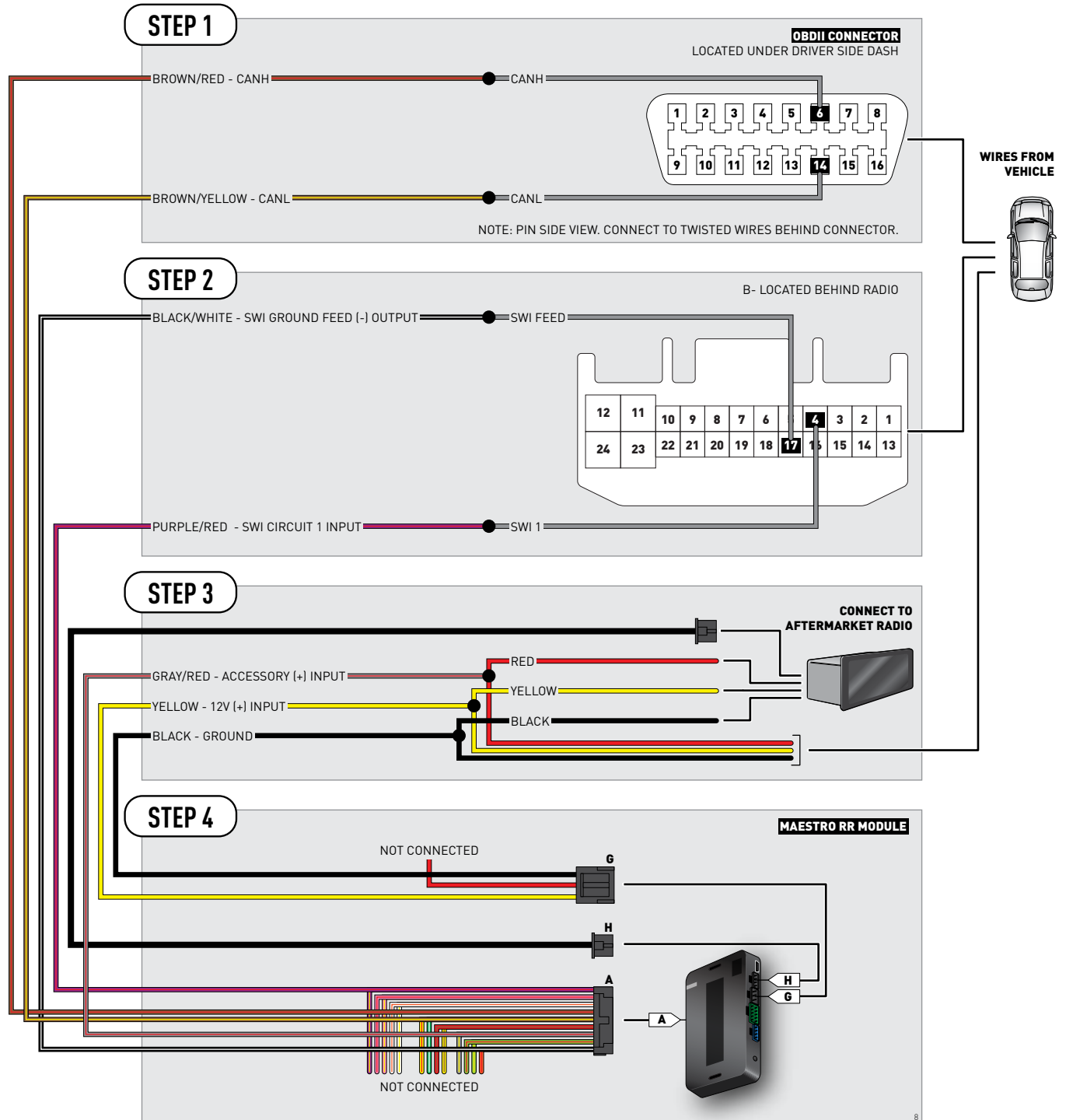

VEHICLE WIRE REFERENCE CHART

Wire Description	Connector Name	Connector Color	Connector Type	Position	Wire Color	Polarity	Wire Location
CanH	A	~	16 pin	06	White	[DATA]	OBDII connector, under driver side dash
CanL	A	~	16 pin	14	Yellow	[DATA]	OBDII connector, under driver side dash
SWI 1	B	~	24 pin	04	Brown	[DATA]	Behind radio
SWI Feed	B	~	24 pin	17	Green	(-)	Behind radio



INSTALL GUIDE KIA RIO BASE 2008-2011

RETAINS STEERING WHEEL CONTROLS AND ADDS GAUGES



PRODUCTS REQUIRED

iDatalink Maestro RR Radio Replacement Interface
iDatalink Compatible Radio

OPTIONAL ACCESSORIES

None

PROGRAMMED FIRMWARE

ADS-RR(SI)-HYU01-DS

NOTICE: Automotive Data Solutions Inc. (ADS) recommends having this installation performed by a certified technician. Logos and trademarks used here in are the properties of their respective owners.

WELCOME

Congratulations on the purchase of your iDatalink Maestro RR Radio replacement solution. You are now a few simple steps away from enjoying your new car radio with enhanced features.

Before starting your installation, please ensure that your iDatalink Maestro module is programmed with the correct firmware for your vehicle and that you carefully review the install guide.

Please note that Maestro RR will only retain functionalities that were originally available in the vehicle.

NEED HELP?

 **1 866 427-2999**

 support@idatalink.com

 maestro.idatalink.com/support
www.12voltdata.com/forum

TABLE OF CONTENTS

Wiring Diagram	3
Vehicle Wire Reference Chart	4

WIRING DIAGRAM

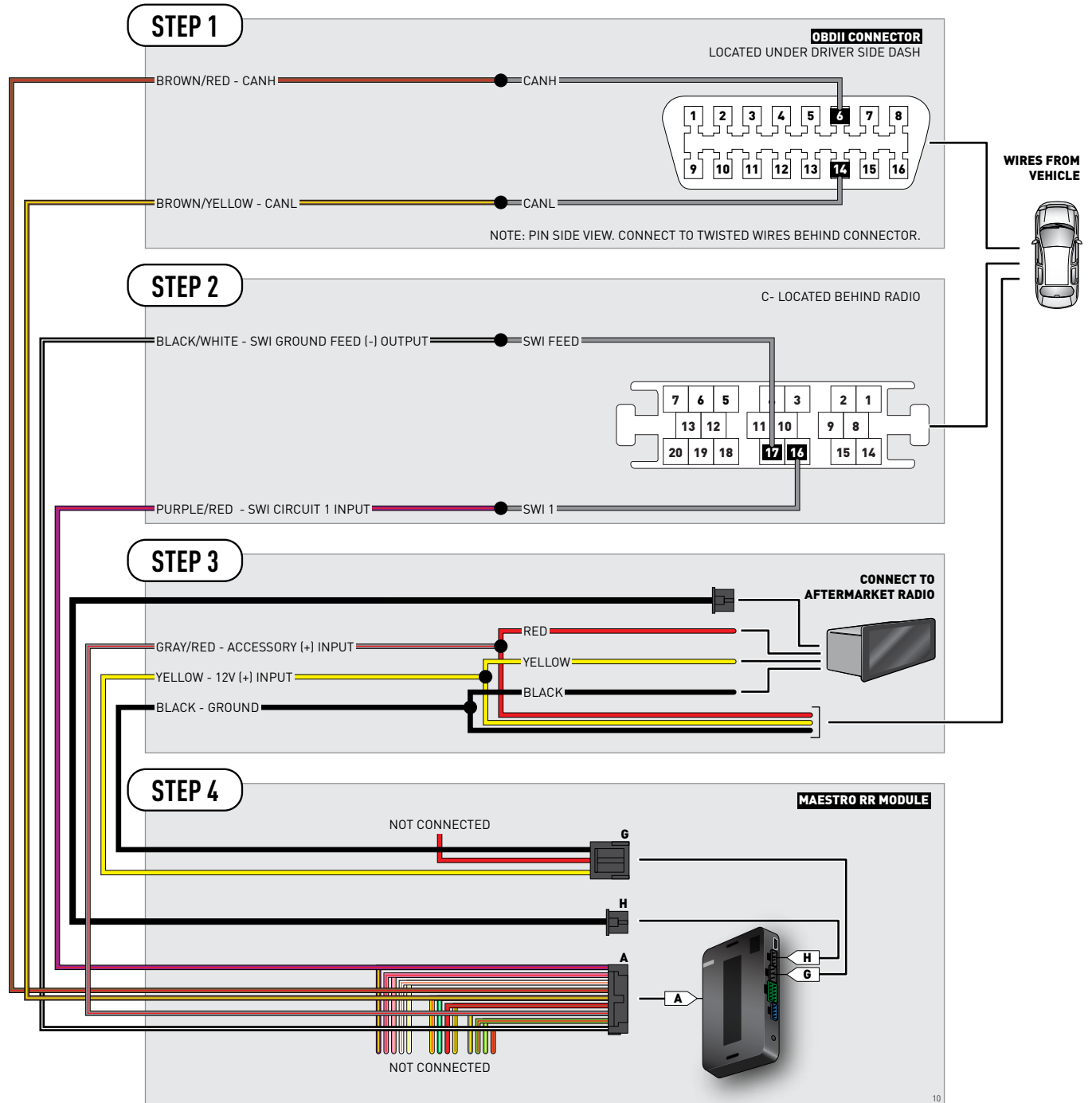

VEHICLE WIRE REFERENCE CHART

Wire Description	Connector Name	Connector Color	Connector Type	Position	Wire Color	Polarity	Wire Location
CanH	A	~	16 pin	06	Red	(DATA)	OBDII connector, under driver side dash
CanL	A	~	16 pin	14	Blue	(DATA)	OBDII connector, under driver side dash
SWI 1	C	~	20 pin	16	Red/Orange	(DATA)	Behind radio
SWI Feed	C	~	20 pin	17	Yellow/Orange	(-)	Behind radio



INSTALL GUIDE KIA RIO BASE 2012-2014

RETAINS STEERING WHEEL CONTROLS AND ADDS GAUGES



PRODUCTS REQUIRED

iDatalink Maestro RR Radio Replacement Interface
iDatalink Compatible Radio

OPTIONAL ACCESSORIES

None

PROGRAMMED FIRMWARE

ADS-RR(SI)-HYU01-DS

NOTICE: Automotive Data Solutions Inc. (ADS) recommends having this installation performed by a certified technician. Logos and trademarks used here in are the properties of their respective owners.

WELCOME

Congratulations on the purchase of your iDatalink Maestro RR Radio replacement solution. You are now a few simple steps away from enjoying your new car radio with enhanced features.

Before starting your installation, please ensure that your iDatalink Maestro module is programmed with the correct firmware for your vehicle and that you carefully review the install guide.

Please note that Maestro RR will only retain functionalities that were originally available in the vehicle.

NEED HELP?

 **1 866 427-2999**

 support@idatalink.com

 maestro.idatalink.com/support
www.12voltdata.com/forum

TABLE OF CONTENTS

Wiring Diagram	3
Vehicle Wire Reference Chart	4

WIRING DIAGRAM

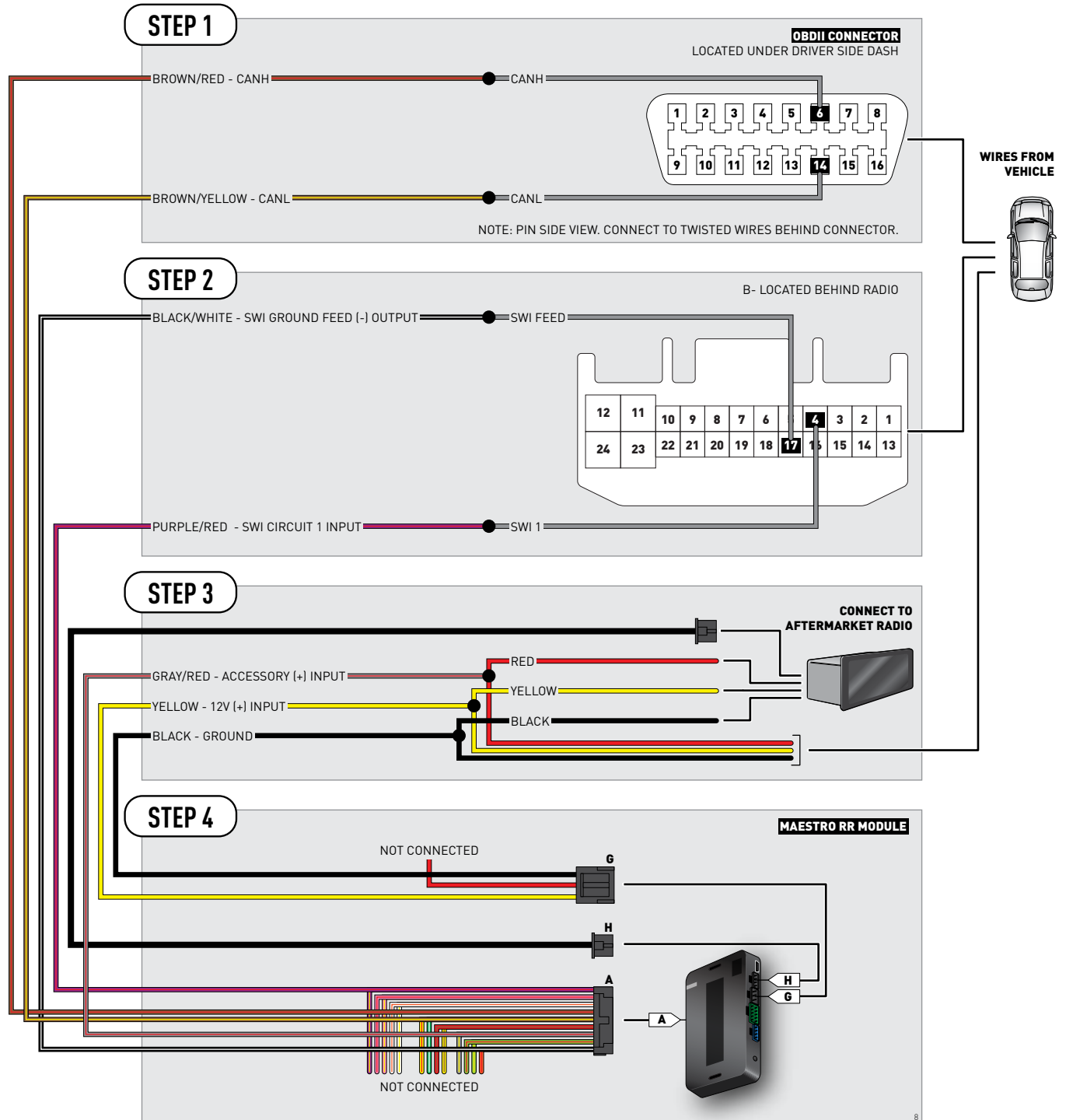

VEHICLE WIRE REFERENCE CHART

Wire Description	Connector Name	Connector Color	Connector Type	Position	Wire Color	Polarity	Wire Location
CanH	A	~	16 pin	06	Red	[DATA]	OBDII connector, under driver side dash
CanL	A	~	16 pin	14	Blue	[DATA]	OBDII connector, under driver side dash
SWI 1	B	~	24 pin	04	Pink	[DATA]	Behind radio
SWI Feed	B	~	24 pin	17	Gray	(-)	Behind radio



INSTALL GUIDE KIA RIO5 BASE 2008-2011

RETAINS STEERING WHEEL CONTROLS AND ADDS GAUGES



PRODUCTS REQUIRED

iDatalink Maestro RR Radio Replacement Interface
iDatalink Compatible Radio

OPTIONAL ACCESSORIES

None

PROGRAMMED FIRMWARE

ADS-RR(SI)-HYU01-DS

NOTICE: Automotive Data Solutions Inc. (ADS) recommends having this installation performed by a certified technician. Logos and trademarks used here in are the properties of their respective owners.

WELCOME

Congratulations on the purchase of your iDatalink Maestro RR Radio replacement solution. You are now a few simple steps away from enjoying your new car radio with enhanced features.

Before starting your installation, please ensure that your iDatalink Maestro module is programmed with the correct firmware for your vehicle and that you carefully review the install guide.

Please note that Maestro RR will only retain functionalities that were originally available in the vehicle.

NEED HELP?

 **1 866 427-2999**

 support@idatalink.com

 maestro.idatalink.com/support
www.12voltdata.com/forum

TABLE OF CONTENTS

Wiring Diagram	3
Vehicle Wire Reference Chart	4

WIRING DIAGRAM

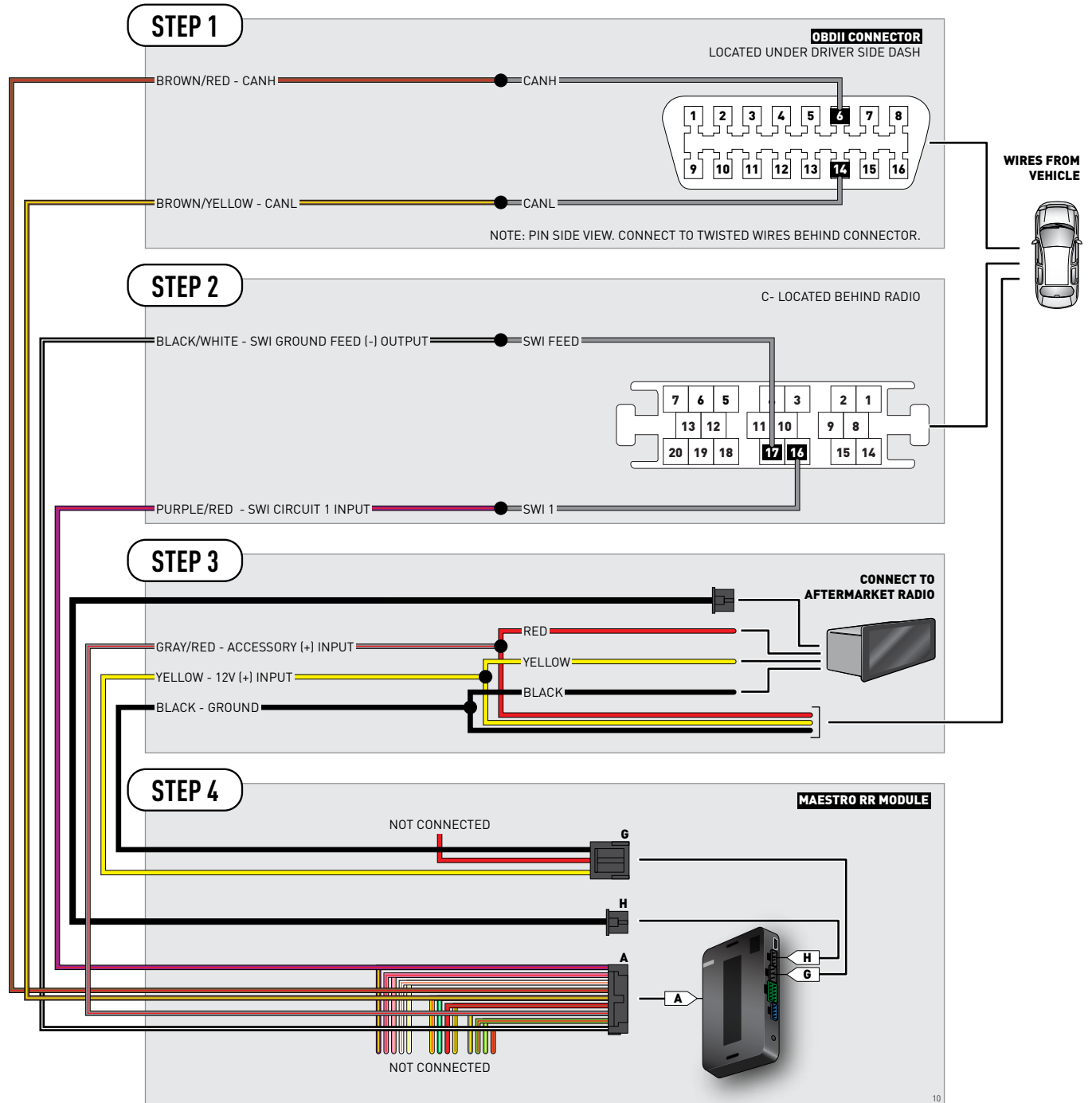

VEHICLE WIRE REFERENCE CHART

Wire Description	Connector Name	Connector Color	Connector Type	Position	Wire Color	Polarity	Wire Location
CanH	A	~	16 pin	06	Red	(DATA)	OBDII connector, under driver side dash
CanL	A	~	16 pin	14	Blue	(DATA)	OBDII connector, under driver side dash
SWI 1	C	~	20 pin	16	Red/Orange	(DATA)	Behind radio
SWI Feed	C	~	20 pin	17	Yellow/Orange	(-)	Behind radio



INSTALL GUIDE KIA RIO5 BASE 2012-2014

RETAINS STEERING WHEEL CONTROLS AND ADDS GAUGES



PRODUCTS REQUIRED

iDatalink Maestro RR Radio Replacement Interface
iDatalink Compatible Radio

OPTIONAL ACCESSORIES

None

PROGRAMMED FIRMWARE

ADS-RR(SI)-HYU01-DS

NOTICE: Automotive Data Solutions Inc. (ADS) recommends having this installation performed by a certified technician. Logos and trademarks used here in are the properties of their respective owners.

WELCOME

Congratulations on the purchase of your iDatalink Maestro RR Radio replacement solution. You are now a few simple steps away from enjoying your new car radio with enhanced features.

Before starting your installation, please ensure that your iDatalink Maestro module is programmed with the correct firmware for your vehicle and that you carefully review the install guide.

Please note that Maestro RR will only retain functionalities that were originally available in the vehicle.

NEED HELP?

 **1 866 427-2999**

 support@idatalink.com

 maestro.idatalink.com/support
www.12voltdata.com/forum

TABLE OF CONTENTS

Wiring Diagram	3
Vehicle Wire Reference Chart	4

WIRING DIAGRAM

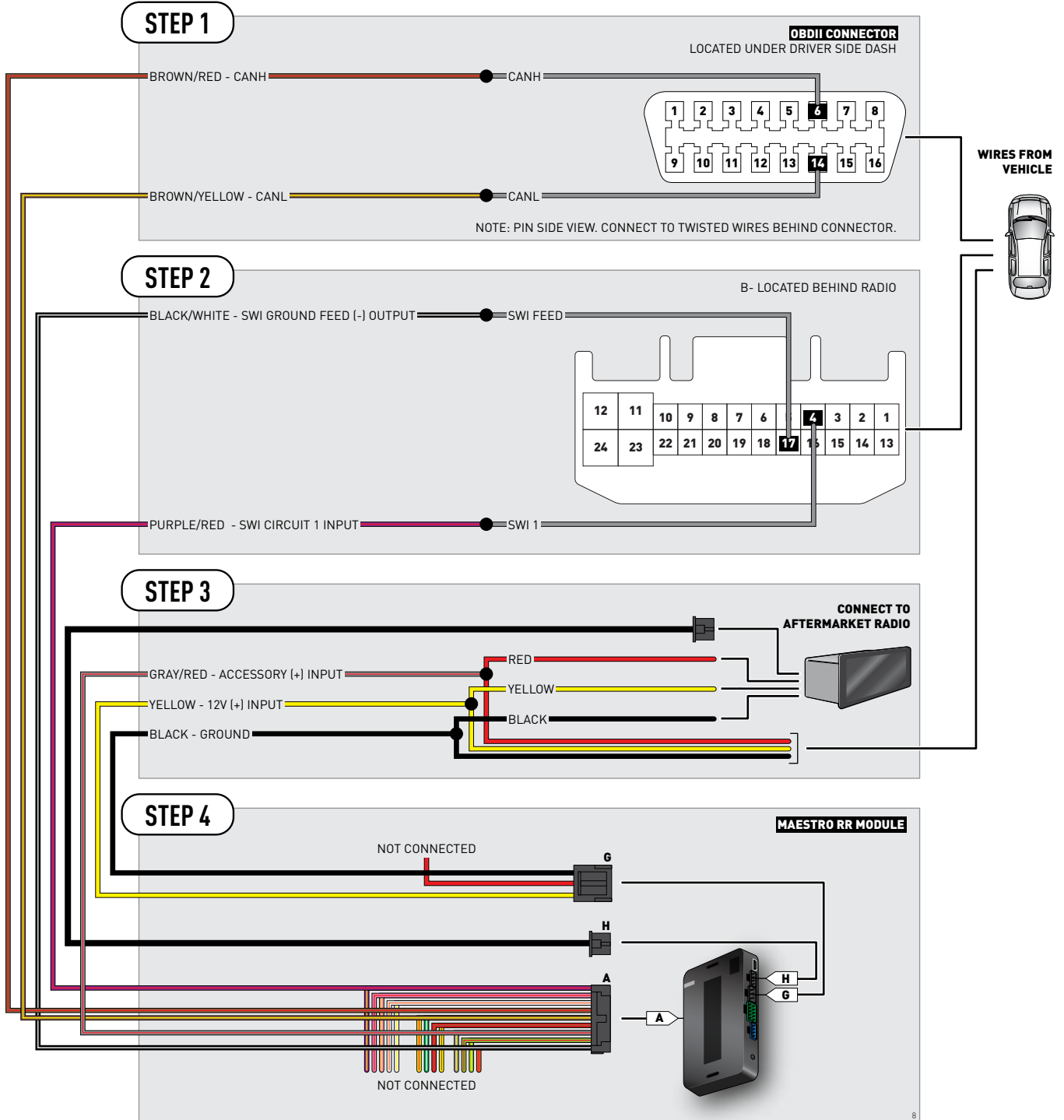

VEHICLE WIRE REFERENCE CHART

Wire Description	Connector Name	Connector Color	Connector Type	Position	Wire Color	Polarity	Wire Location
CanH	A	~	16 pin	06	Red	[DATA]	OBDII connector, under driver side dash
CanL	A	~	16 pin	14	Blue	[DATA]	OBDII connector, under driver side dash
SWI 1	B	~	24 pin	04	Pink	[DATA]	Behind radio
SWI Feed	B	~	24 pin	17	Gray	(-)	Behind radio



INSTALL GUIDE KIA RONDO BASE 2007-2011

RETAINS STEERING WHEEL CONTROLS AND ADDS GAUGES



PRODUCTS REQUIRED

iDatalink Maestro RR Radio Replacement Interface
iDatalink Compatible Radio

OPTIONAL ACCESSORIES

None

PROGRAMMED FIRMWARE

ADS-RR(SI)-HYU01-DS

NOTICE: Automotive Data Solutions Inc. (ADS) recommends having this installation performed by a certified technician. Logos and trademarks used here in are the properties of their respective owners.

WELCOME

Congratulations on the purchase of your iDatalink Maestro RR Radio replacement solution. You are now a few simple steps away from enjoying your new car radio with enhanced features.

Before starting your installation, please ensure that your iDatalink Maestro module is programmed with the correct firmware for your vehicle and that you carefully review the install guide.

Please note that Maestro RR will only retain functionalities that were originally available in the vehicle.

NEED HELP?

 **1 866 427-2999**

 support@idatalink.com

 maestro.idatalink.com/support
www.12voltdata.com/forum

TABLE OF CONTENTS

Wiring Diagram	3
Vehicle Wire Reference Chart	4

WIRING DIAGRAM

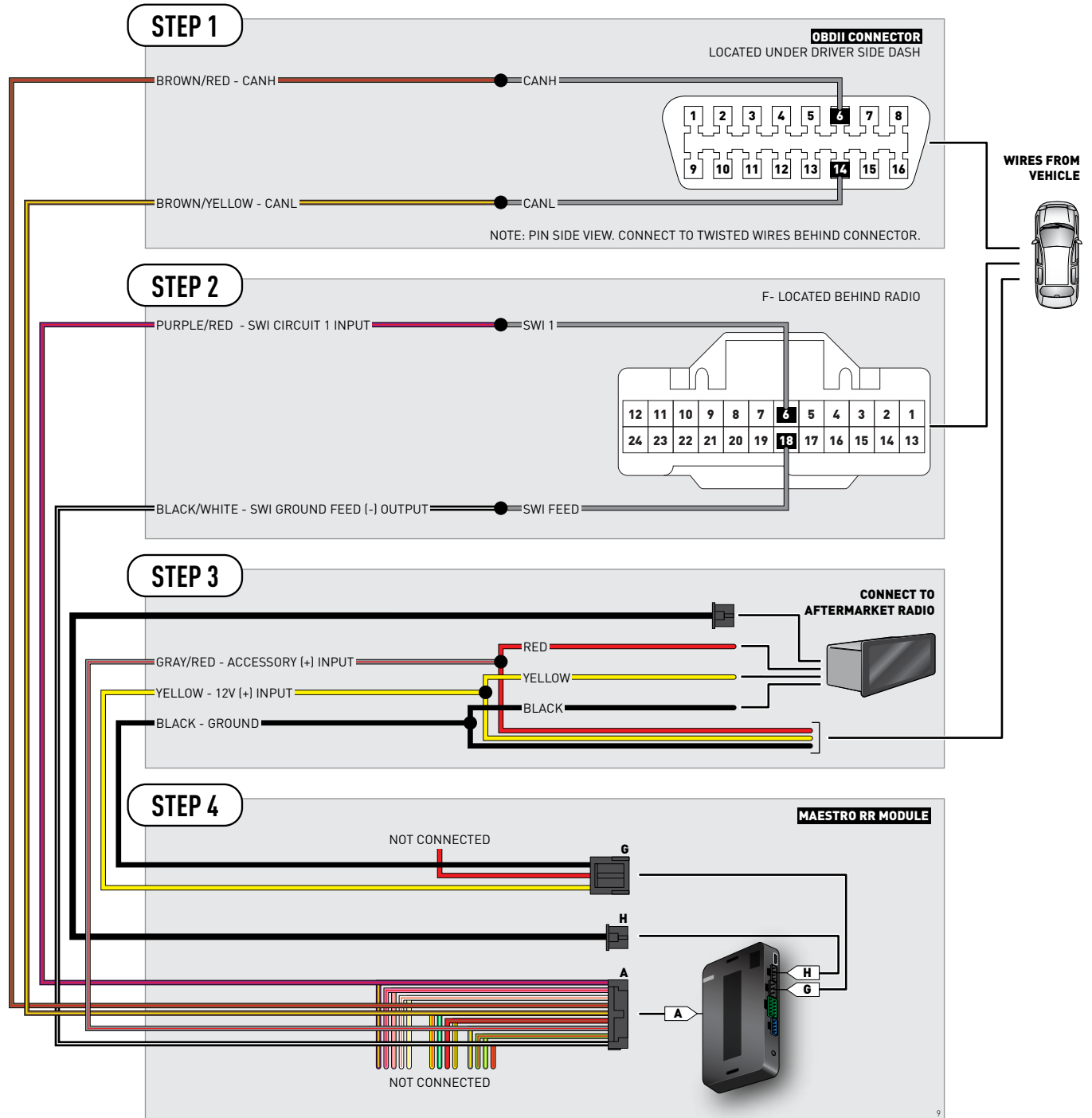

VEHICLE WIRE REFERENCE CHART

Wire Description	Connector Name	Connector Color	Connector Type	Position	Wire Color	Polarity	Wire Location
CanH	A	~	16 pin	06	Red	(DATA)	OBDII connector, under driver side dash
CanL	A	~	16 pin	14	Blue	(DATA)	OBDII connector, under driver side dash
SWI 1	F	~	24 pin	06	White	(DATA)	Behind radio
SWI Feed	F	~	24 pin	18	White/Black	(-)	Behind radio



INSTALL GUIDE KIA SEDONA BASE 2009-2012

RETAINS STEERING WHEEL CONTROLS AND ADDS GAUGES



PRODUCTS REQUIRED

iDatalink Maestro RR Radio Replacement Interface
iDatalink Compatible Radio

OPTIONAL ACCESSORIES

None

PROGRAMMED FIRMWARE

ADS-RR(SI)-HYU01-DS

NOTICE: Automotive Data Solutions Inc. (ADS) recommends having this installation performed by a certified technician. Logos and trademarks used here in are the properties of their respective owners.

WELCOME

Congratulations on the purchase of your iDatalink Maestro RR Radio replacement solution. You are now a few simple steps away from enjoying your new car radio with enhanced features.

Before starting your installation, please ensure that your iDatalink Maestro module is programmed with the correct firmware for your vehicle and that you carefully review the install guide.

Please note that Maestro RR will only retain functionalities that were originally available in the vehicle.

NEED HELP?

 **1 866 427-2999**

 **support@idatalink.com**

 **maestro.idatalink.com/support
www.12voltdata.com/forum**

TABLE OF CONTENTS

Wiring Diagram	3
Vehicle Wire Reference Chart	4

WIRING DIAGRAM

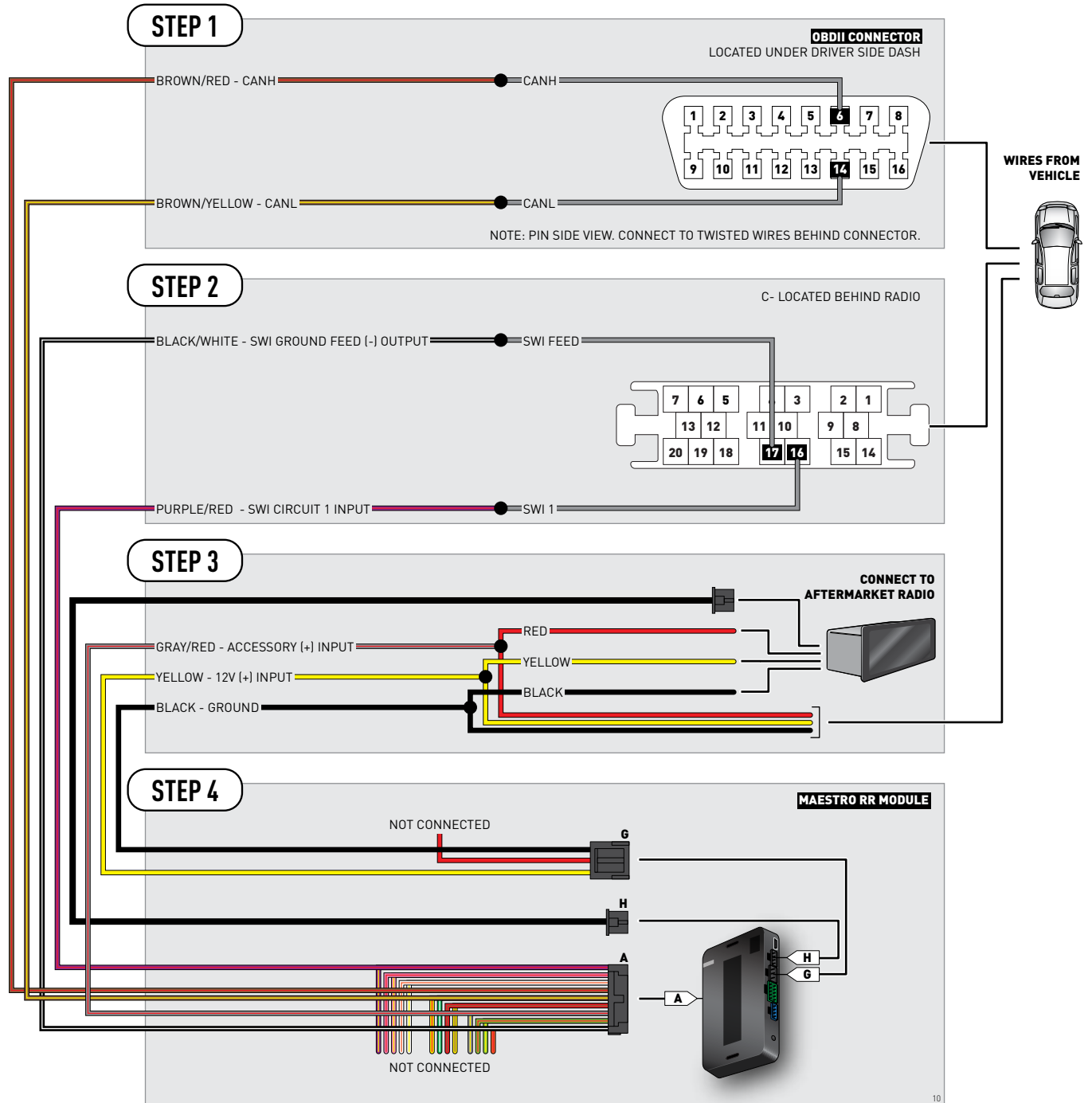

VEHICLE WIRE REFERENCE CHART

Wire Description	Connector Name	Connector Color	Connector Type	Position	Wire Color	Polarity	Wire Location
CanH	A	~	16 pin	06	Blue	(DATA)	OBDII connector, under driver side dash
CanL	A	~	16 pin	14	Orange	(DATA)	OBDII connector, under driver side dash
SWI 1	C	~	20 pin	16	Blue/Black	(DATA)	Behind radio
SWI Feed	C	~	20 pin	17	Red	(-)	Behind radio



INSTALL GUIDE KIA SORENTO BASE 2011-2013

RETAINS STEERING WHEEL CONTROLS AND ADDS GAUGES



PRODUCTS REQUIRED

iDatalink Maestro RR Radio Replacement Interface
iDatalink Compatible Radio

OPTIONAL ACCESSORIES

None

PROGRAMMED FIRMWARE

ADS-RR(SI)-HYU01-DS

NOTICE: Automotive Data Solutions Inc. (ADS) recommends having this installation performed by a certified technician. Logos and trademarks used here in are the properties of their respective owners.

WELCOME

Congratulations on the purchase of your iDatalink Maestro RR Radio replacement solution. You are now a few simple steps away from enjoying your new car radio with enhanced features.

Before starting your installation, please ensure that your iDatalink Maestro module is programmed with the correct firmware for your vehicle and that you carefully review the install guide.

Please note that Maestro RR will only retain functionalities that were originally available in the vehicle.

NEED HELP?

 **1 866 427-2999**

 support@idatalink.com

 maestro.idatalink.com/support
www.12voltdata.com/forum

TABLE OF CONTENTS

Wiring Diagram	3
Vehicle Wire Reference Chart	4

WIRING DIAGRAM

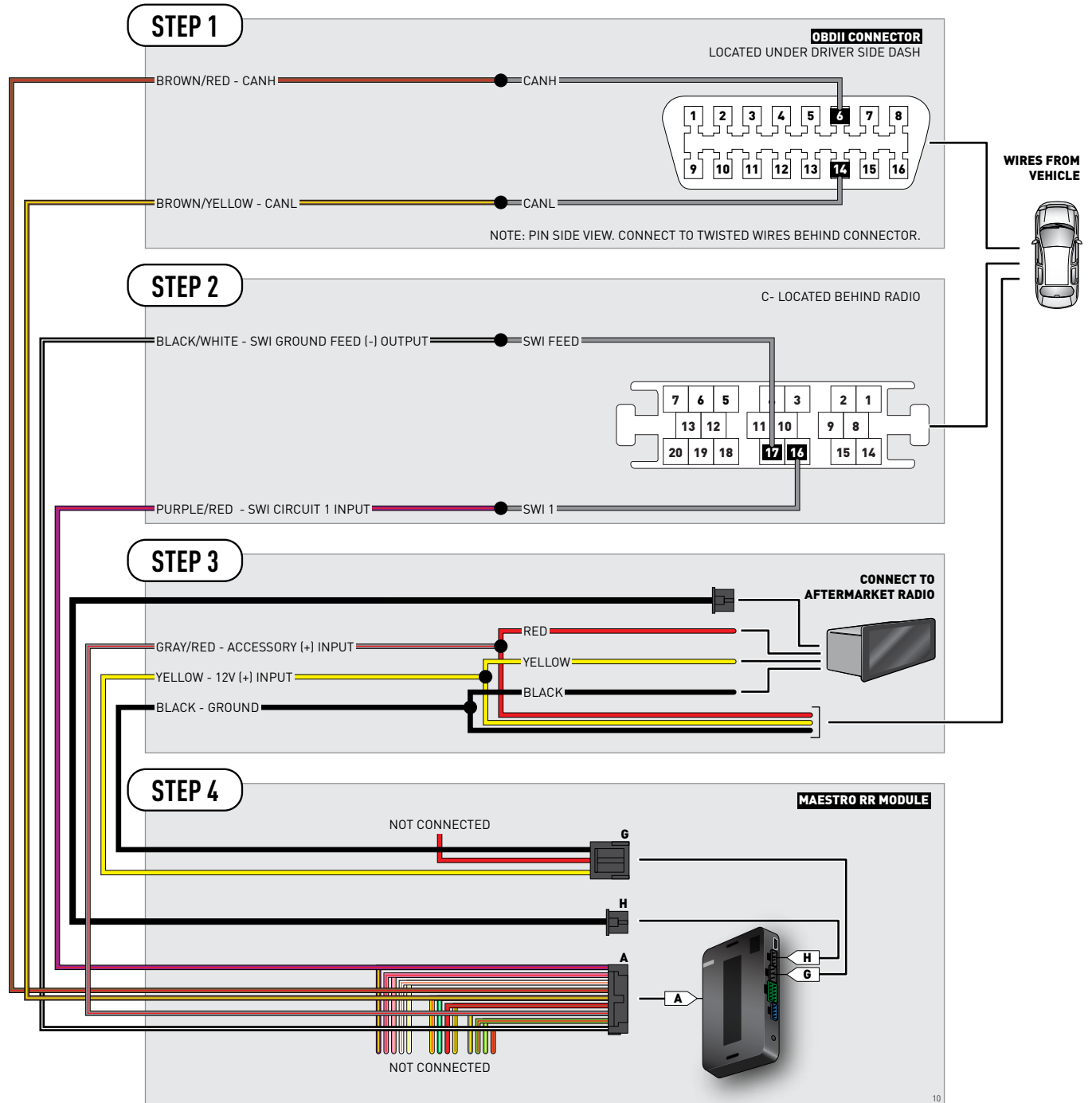

VEHICLE WIRE REFERENCE CHART

Wire Description	Connector Name	Connector Color	Connector Type	Position	Wire Color	Polarity	Wire Location
CanH	A	~	16 pin	06	White	[DATA]	OBDII connector, under driver side dash
CanL	A	~	16 pin	14	Red	[DATA]	OBDII connector, under driver side dash
SWI 1	C	~	20 pin	16	Blue	[DATA]	Behind radio
SWI Feed	C	~	20 pin	17	Gray	(-)	Behind radio



INSTALL GUIDE KIA SORENTO BASE 2014

RETAINS STEERING WHEEL CONTROLS AND ADDS GAUGES



PRODUCTS REQUIRED

iDatalink Maestro RR Radio Replacement Interface
iDatalink Compatible Radio

OPTIONAL ACCESSORIES

None

PROGRAMMED FIRMWARE

ADS-RR(SI)-HYU01-DS

NOTICE: Automotive Data Solutions Inc. (ADS) recommends having this installation performed by a certified technician. Logos and trademarks used here in are the properties of their respective owners.

WELCOME

Congratulations on the purchase of your iDatalink Maestro RR Radio replacement solution. You are now a few simple steps away from enjoying your new car radio with enhanced features.

Before starting your installation, please ensure that your iDatalink Maestro module is programmed with the correct firmware for your vehicle and that you carefully review the install guide.

Please note that Maestro RR will only retain functionalities that were originally available in the vehicle.

NEED HELP?

 **1 866 427-2999**

 **support@idatalink.com**

 **maestro.idatalink.com/support
www.12voltdata.com/forum**

TABLE OF CONTENTS

Wiring Diagram	3
Vehicle Wire Reference Chart	4

WIRING DIAGRAM

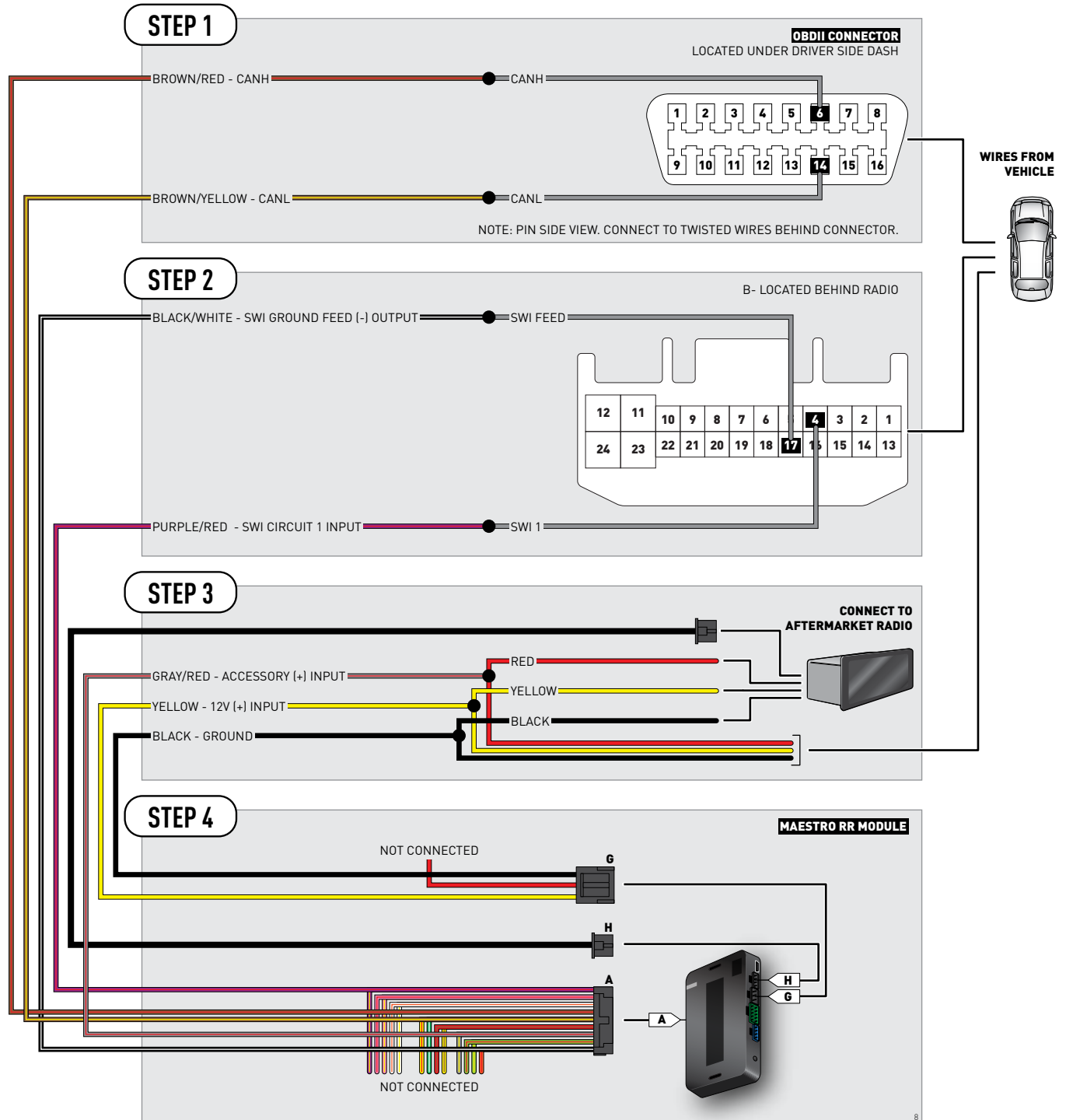

VEHICLE WIRE REFERENCE CHART

Wire Description	Connector Name	Connector Color	Connector Type	Position	Wire Color	Polarity	Wire Location
CanH	A	~	16 pin	06	White	[DATA]	OBDII connector, under driver side dash
CanL	A	~	16 pin	14	Red	[DATA]	OBDII connector, under driver side dash
SWI 1	B	~	24 pin	04	Blue	[DATA]	Behind radio
SWI Feed	B	~	24 pin	17	Orange	(-)	Behind radio



INSTALL GUIDE KIA SOUL BASE 2010-2011

RETAINS STEERING WHEEL CONTROLS AND ADDS GAUGES



PRODUCTS REQUIRED

iDatalink Maestro RR Radio Replacement Interface
iDatalink Compatible Radio

OPTIONAL ACCESSORIES

None

PROGRAMMED FIRMWARE

ADS-RR(SI)-HYU01-DS

NOTICE: Automotive Data Solutions Inc. (ADS) recommends having this installation performed by a certified technician. Logos and trademarks used here in are the properties of their respective owners.

WELCOME

Congratulations on the purchase of your iDatalink Maestro RR Radio replacement solution. You are now a few simple steps away from enjoying your new car radio with enhanced features.

Before starting your installation, please ensure that your iDatalink Maestro module is programmed with the correct firmware for your vehicle and that you carefully review the install guide.

Please note that Maestro RR will only retain functionalities that were originally available in the vehicle.

NEED HELP?

 **1 866 427-2999**

 support@idatalink.com

 maestro.idatalink.com/support
www.12voltdata.com/forum

TABLE OF CONTENTS

Wiring Diagram	3
Vehicle Wire Reference Chart	4

WIRING DIAGRAM

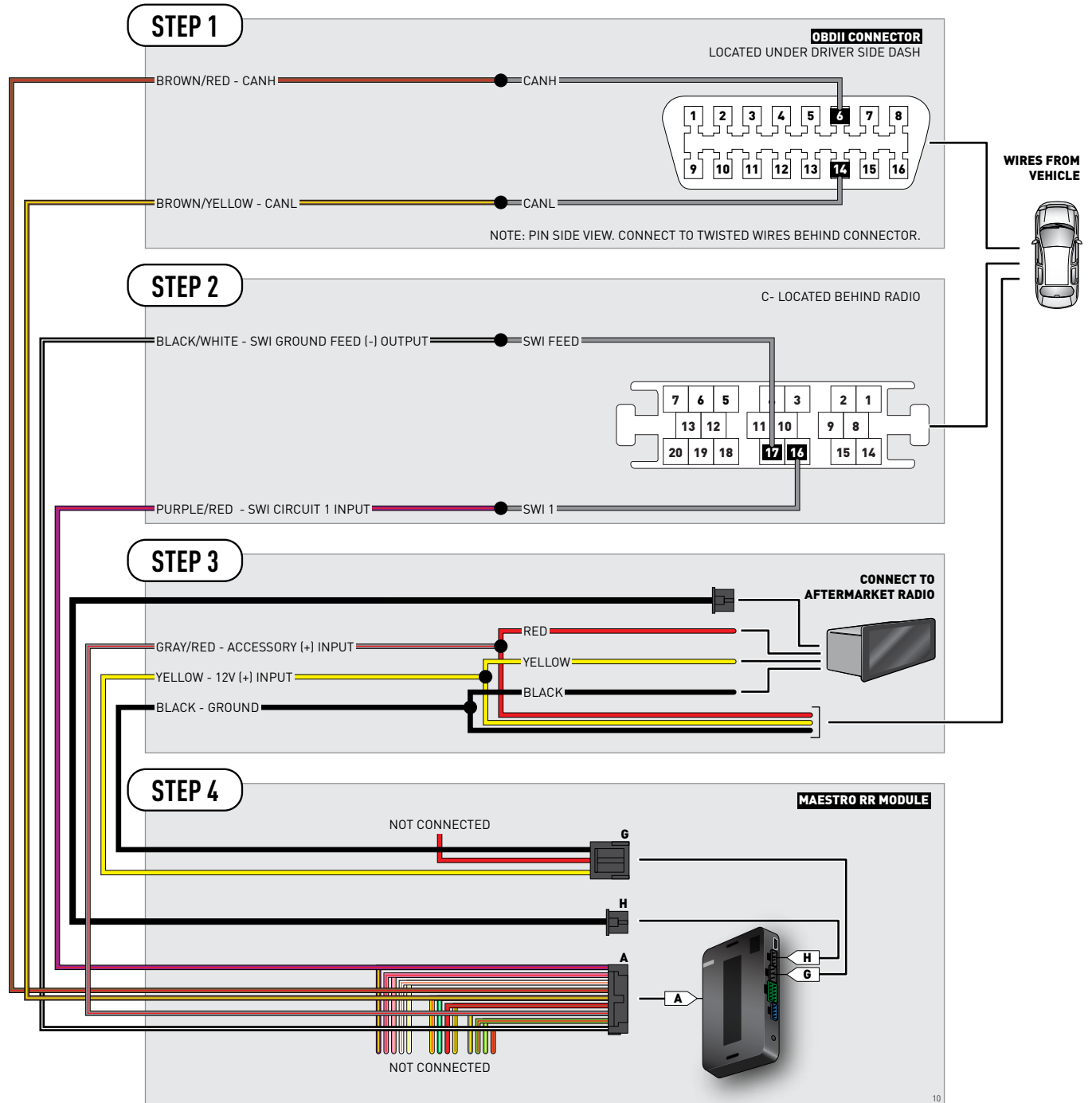

VEHICLE WIRE REFERENCE CHART

Wire Description	Connector Name	Connector Color	Connector Type	Position	Wire Color	Polarity	Wire Location
CanH	A	~	16 pin	06	Red	(DATA)	OBDII connector, under driver side dash
CanL	A	~	16 pin	14	Blue	(DATA)	OBDII connector, under driver side dash
SWI 1	C	~	20 pin	16	Orange	(DATA)	Behind radio
SWI Feed	C	~	20 pin	17	Blue	(-)	Behind radio



INSTALL GUIDE KIA SOUL BASE 2012-2013

RETAINS STEERING WHEEL CONTROLS AND ADDS GAUGES



PRODUCTS REQUIRED

iDatalink Maestro RR Radio Replacement Interface
iDatalink Compatible Radio

OPTIONAL ACCESSORIES

None

PROGRAMMED FIRMWARE

ADS-RR(SI)-HYU01-DS

NOTICE: Automotive Data Solutions Inc. (ADS) recommends having this installation performed by a certified technician. Logos and trademarks used here in are the properties of their respective owners.

WELCOME

Congratulations on the purchase of your iDatalink Maestro RR Radio replacement solution. You are now a few simple steps away from enjoying your new car radio with enhanced features.

Before starting your installation, please ensure that your iDatalink Maestro module is programmed with the correct firmware for your vehicle and that you carefully review the install guide.

Please note that Maestro RR will only retain functionalities that were originally available in the vehicle.

NEED HELP?

 **1 866 427-2999**

 **support@idatalink.com**

 **maestro.idatalink.com/support
www.12voltdata.com/forum**

TABLE OF CONTENTS

Wiring Diagram	3
Vehicle Wire Reference Chart	4

WIRING DIAGRAM

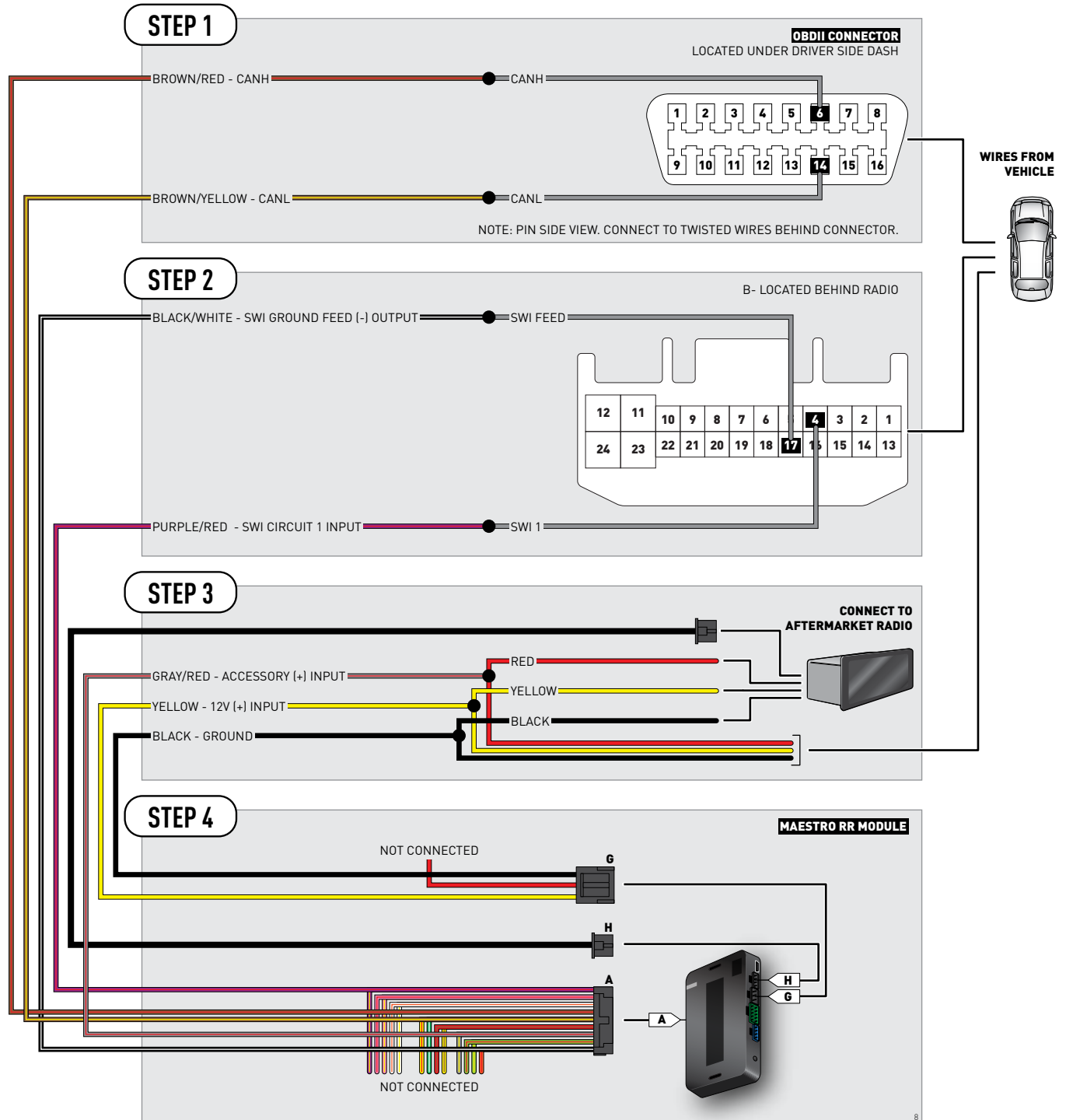

VEHICLE WIRE REFERENCE CHART

Wire Description	Connector Name	Connector Color	Connector Type	Position	Wire Color	Polarity	Wire Location
CanH	A	~	16 pin	06	Blue	(DATA)	OBDII connector, under driver side dash
CanL	A	~	16 pin	14	Red	(DATA)	OBDII connector, under driver side dash
SWI 1	B	~	24 pin	04	Orange	(DATA)	Behind radio
SWI Feed	B	~	24 pin	17	Blue	(-)	Behind radio



INSTALL GUIDE KIA SOUL BASE 2014

RETAINS STEERING WHEEL CONTROLS AND ADDS GAUGES



PRODUCTS REQUIRED

iDatalink Maestro RR Radio Replacement Interface
iDatalink Compatible Radio

OPTIONAL ACCESSORIES

None

PROGRAMMED FIRMWARE

ADS-RR(SI)-HYU01-DS

NOTICE: Automotive Data Solutions Inc. (ADS) recommends having this installation performed by a certified technician. Logos and trademarks used here in are the properties of their respective owners.

WELCOME

Congratulations on the purchase of your iDatalink Maestro RR Radio replacement solution. You are now a few simple steps away from enjoying your new car radio with enhanced features.

Before starting your installation, please ensure that your iDatalink Maestro module is programmed with the correct firmware for your vehicle and that you carefully review the install guide.

Please note that Maestro RR will only retain functionalities that were originally available in the vehicle.

NEED HELP?

 **1 866 427-2999**

 **support@idatalink.com**

 **maestro.idatalink.com/support
www.12voltdata.com/forum**

TABLE OF CONTENTS

Wiring Diagram	3
Vehicle Wire Reference Chart	4

WIRING DIAGRAM

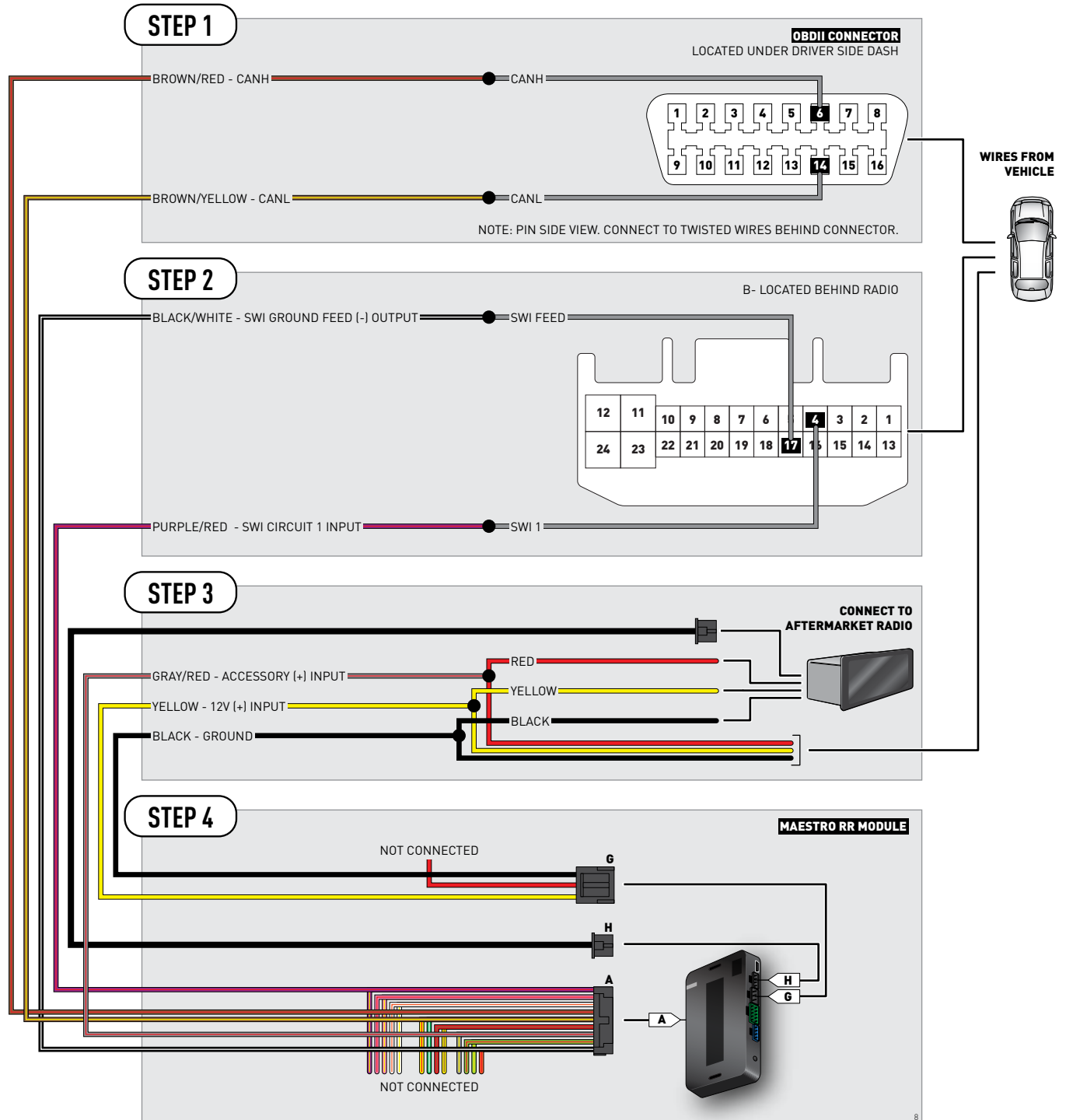

VEHICLE WIRE REFERENCE CHART

Wire Description	Connector Name	Connector Color	Connector Type	Position	Wire Color	Polarity	Wire Location
CanH	A	~	16 pin	06	White	[DATA]	OBDII connector, under driver side dash
CanL	A	~	16 pin	14	Brown	[DATA]	OBDII connector, under driver side dash
SWI 1	B	~	24 pin	04	Brown	[DATA]	Behind radio
SWI Feed	B	~	24 pin	17	Green	(-)	Behind radio



INSTALL GUIDE KIA SPORTAGE BASE 2011-2014

RETAINS STEERING WHEEL CONTROLS AND ADDS GAUGES



PRODUCTS REQUIRED

iDatalink Maestro RR Radio Replacement Interface
iDatalink Compatible Radio

OPTIONAL ACCESSORIES

None

PROGRAMMED FIRMWARE

ADS-RR(SI)-HYU01-DS

NOTICE: Automotive Data Solutions Inc. (ADS) recommends having this installation performed by a certified technician. Logos and trademarks used here in are the properties of their respective owners.

WELCOME

Congratulations on the purchase of your iDatalink Maestro RR Radio replacement solution. You are now a few simple steps away from enjoying your new car radio with enhanced features.

Before starting your installation, please ensure that your iDatalink Maestro module is programmed with the correct firmware for your vehicle and that you carefully review the install guide.

Please note that Maestro RR will only retain functionalities that were originally available in the vehicle.

NEED HELP?

 **1 866 427-2999**

 **support@idatalink.com**

 **maestro.idatalink.com/support
www.12voltdata.com/forum**

TABLE OF CONTENTS

Wiring Diagram	3
Vehicle Wire Reference Chart	4

WIRING DIAGRAM

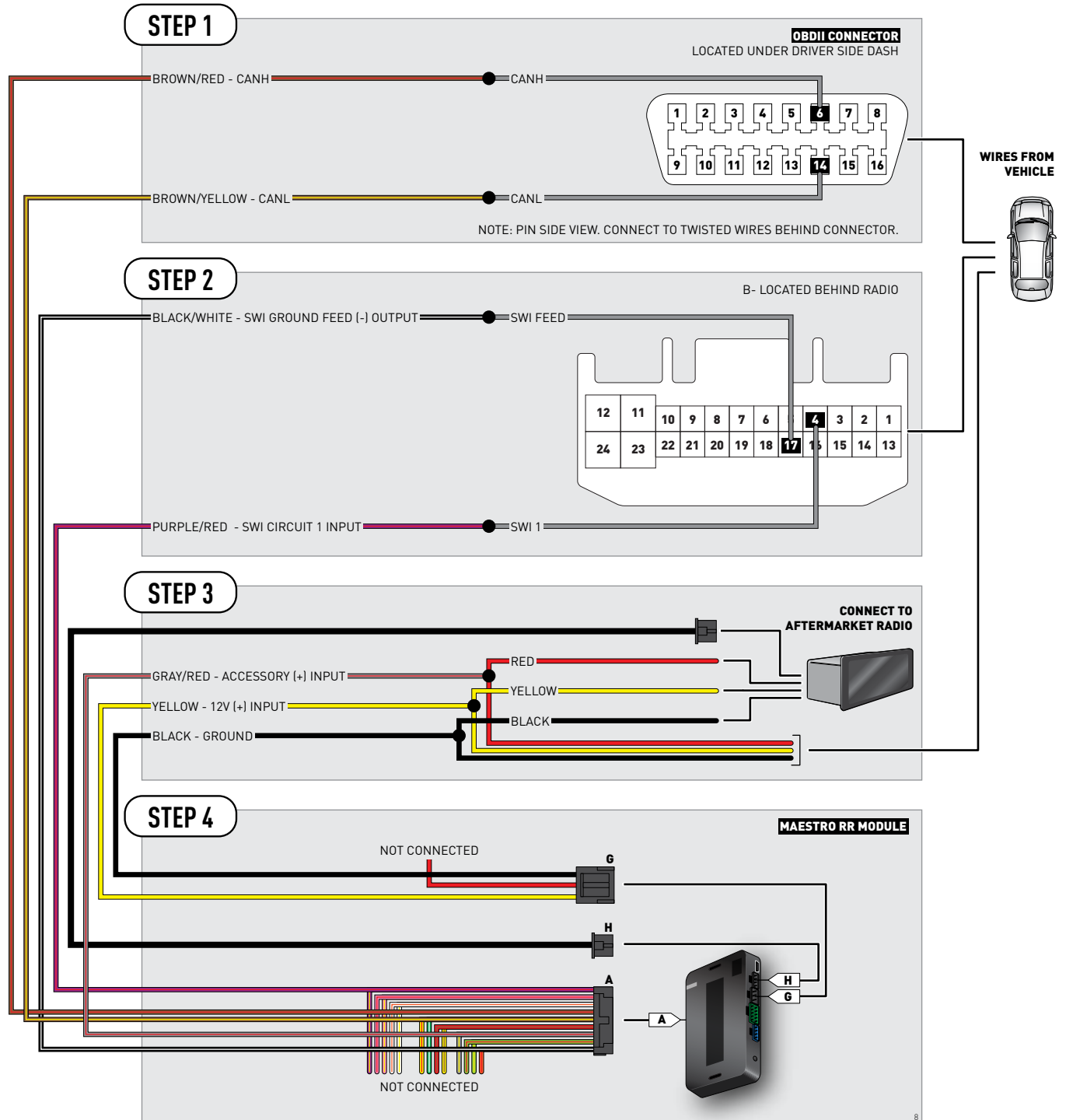

VEHICLE WIRE REFERENCE CHART

Wire Description	Connector Name	Connector Color	Connector Type	Position	Wire Color	Polarity	Wire Location
CanH	A	~	16 pin	06	Green	(DATA)	OBDII connector, under driver side dash
CanL	A	~	16 pin	14	Orange	(DATA)	OBDII connector, under driver side dash
SWI 1	B	~	24 pin	04	Blue	(DATA)	Behind radio
SWI Feed	B	~	24 pin	17	Gray	(-)	Behind radio